



**AFTER MARKET      1949-2010**

**TENNECO**



**N**ew Company, new Challenge, new Vision same Mission  
On September 1st Marzocchi Suspension became part of the Tenneco Inc. Group, a \$6.2 billion global manufacturing company with headquarters in Lake Forest, Illinois and approximately 21,000 employees worldwide. Tenneco is one of the world's largest designers, manufacturers and marketers of emission control (exhaust systems) and ride control products (suspension) and systems for the automotive original equipment market. Tenneco markets its products principally under the Monroe®, Rancho, Walker®, Gillet™ and Clevite®Elastomer brand names.

What does this mean for the valuable and famous Mountain Bike suspension division? According to Bryson Martin, VP and founder of Marzocchi Suspension USA, business is as usual but with one exception; we now have the horse power of a 6.2 billion dollar company with 21,000 employees we can tap into with extensive manufacturing and engineering experience in the suspension business. Unlike other recent acquisitions or equity partnerships with other suspension companies, we have partnered up with a massive suspension manufacturing company that will assist us in becoming even stronger and more dominant in our market with the help of their manufacturing capabilities to ensure long term success. Conversely, having an equity partner just means you must perform financially in the short term and with manufacturing costs rising coupled with a deteriorating economy, delivering quarterly shareholder profits must come at cutting costs or increasing market share. Tenneco has incredible business talent and

with any other company they've acquired was directed at strengthening the entire Tenneco organization and not just their balance sheet. From the outside looking in, Tenneco has all the appearances of a company that can gobble up and dilute such a small entity as Marzocchi. That's just not the case; the persons we have been dealing with and have known for several years are far from corporate and having a high end niche brand like Marzocchi is exciting for them as well. Tenneco knows that the value of a brand like Marzocchi and the primary goal is to assist us to reduce our manufacturing costs, continuously improve quality, decrease our time to market, while supporting us with an extensive engineering department. It's an exciting time for all of us, since the establishment of the Mountain Bike Division in 1992, our small team has worn many different hats to design, develop, manufacture and bring to market our products. Now, we can focus on our individual strengths and execute on many of our long awaited goals. Tenneco is also very excited about the Mountain Bike market and has no intention to dilute or "corporatize this division" they know that homogenizing the aggressive and market leading image and lifestyle of this division would kill it. That being said, all the employees, many of which have been with the company for over a decade, are still in place and have no intention of departing. As the key employees have stated "Andrea Pierantoni, Bryson Martin, John Pelino, and Fabio Sturaro" the future is so exciting with such a massive resource behind us, there won't be anything that can stop us now!  
[www.tenneco-marzocchi.com](http://www.tenneco-marzocchi.com)

marzocchi marzocchi marzocchi marzocchi marzocchi marzocchi marzocchi marzocchi marzocchi marzocchi

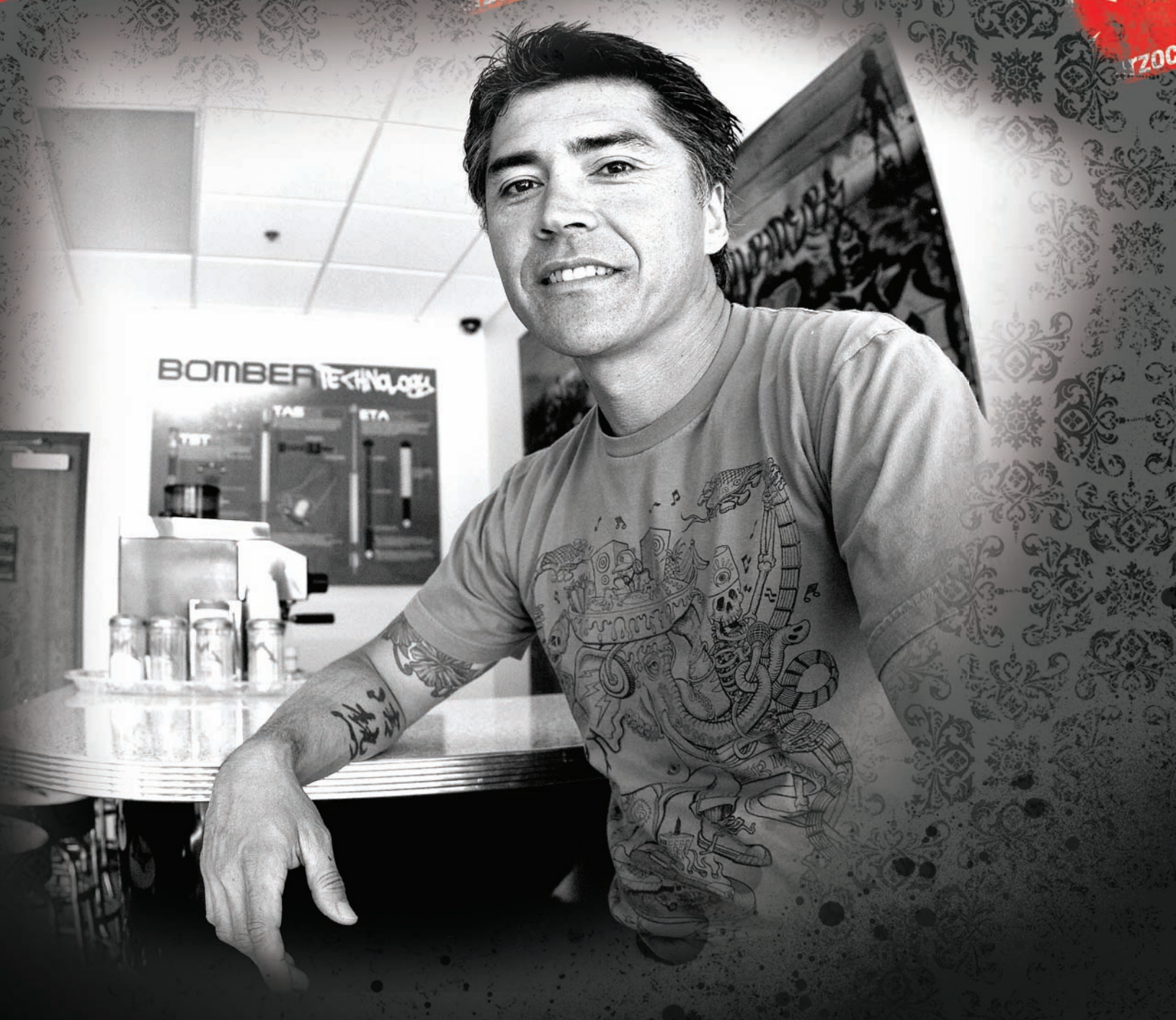

# EIGHT GOOD REASONS TO BE PROUD TO RIDE MARZOCCHI

## 1 - AT MARZOCCHI SAFETY COMES FIRST

In 12 years of Bomber technology the achieved goals in the sport and in production have been many and helped the only European mountain bike suspension manufacture to be awarded as one of the big components vender in the world. Today the Marzocchi range offers to the end consumer 30 different forks and 5 shocks, available in the most common sizes, in order to accomplish all the riders need, starting from the fitness enthusiast to the extreme freerider and downhiller. But the most important thing, that sometimes people don't consider if compared with all the technical features, is the compliance of all the Marzocchi items with the UNI EN 14766\_05 safety norm. A European award that guarantees to the customer premium quality and reliability in all the use condition as long the rider is not abusing the product it self. Machine testing and stress procedure requested by the norm are the most demanding and severe and to be in the position to offer this safety standard for all products is a goal that not all the companies in the market can offer to there customers. Marzocchi accomplish the UNI EN 14766\_05 safety standard since day one with the 2006 line. A goal that gives even more prestige to a brand that plays the role of the protagonist of the Italian industry and design.



## 2 - AT MARZOCCHI PEOPLE CARE ABOUT THE ENVIRONMENT

We love the dirt, but this doesn't mean that we don't want to keep it clean! Working in the bike business made us very careful for all the issues related with the environment. So we started many years ago to convert our facility in Italy first and now the one in Taiwan in order to have the most environmental friendly production possible. Where possible we eliminated plastic parts, and used precious and recyclable metallic alloy instead. We reduced the huge paper user manual offering a more complete and interactive tech area on our website. We used recycled paper for our boxes and all the printings are based on water colors. Now all this became a standard for all the brands all over the world, but we are proud to say that we started years ago!

### 3 - AT MARZOCCHI THE BEST SERVICE IS INCLUDED

Since day one in 1949 Marzocchi believed in a strong relationship between racing and production. Today the same philosophy brings our technician to the most important events all over the world. The Marzocchi truck is always welcome. Courtesy and competence is what all the customer will find when they get in touch with Tom, Ronny, Gideon, Wolfgang, Stéphane, Davide, Lele and Gigi! This people travels the world to keep the all the suspensions bearing the Marzocchi brand in the perfect shape, no matter how many miles have been ridden. And if you want to have the best out of your shocks, just come to say hi, and they will have a pro tip to make you ride like you never thought possible!



### 4 - AT MARZOCCHI COMMITMENT AND DEDICATION TO THE SPORT ARE A MUST

In the last twenty years many riders and events have been sponsored and supported by Marzocchi. Bike Parks world wide joined our program and the yearly Press Camp made the sport even bigger and stronger. Marzocchi invested in the mountain bike sport more then any other suspension company and this made the brand an icon on one side and the bicycle off road business healthy and popular. The performance of the products and the farsighted point of view in designing revolutionary products give a huge contribute to create a life style that goes right to the hart of the passionate riders.



# EIGHT GOOD REASONS TO BE PROUD TO RIDE MARZOCCHI

## 5 - At Marzocchi people believe in the past experience to develop products for the future

In the mountain bike business not many companies can show such a longevity. If we look at the suspension business Marzocchi is the only one that can boast such an experience. Established in 1949 by Guglielmo and Stefano Marzocchi the workshop in Zola Predosa had the important cooperation of awarded motorbike rider like Giacomo Agostini in the 500 cc motogp category, or the chance to drive to victory at the Paris-Dakar race the BMW rider Gaston Rahier in 1983 and the Italian Edi Orioli in 1990 and '94 riding the giant Cagiva Ducati 900. Developed in 1989 and produced in 1990 the first mtb Marzocchi suspension fork was called Star Fork: a revolution for the growing off-road bike business and for Marzocchi too that saw in the same years the extraordinary increase of the export market of suspension, celebrated two years later with the birth of the Marzocchi Suspension Center in California in order to offer the best after-sales service to the US market. In 1995 the company added to the service center a brand new sales office to accomplish the big requests of mountain bike products that became popular thanks to the transfer of the huge motorcycle experience in creating premium suspension. After the first production of Star Forks the XC line established new performance standards, but the revolution was made in 1996 with the Bomber technology, still used today as the base of all the Marzocchi mountain bike projects developed in the tech department in Zola Predosa. Z1, Rac, Shiver, 888 and Roco are names that made history in the mountain bike business and the bikers all over the world consider this as a synonym of a new philosophy to practice the sport, the free ride.



## 6 At Marzocchi all the products are user friendly and easy to maintain

Talking about suspension our mind goes right to the concept of comfort. But feeling comfortable is a wider concept that includes the positioning of feature knobs, range of adjustability, frame compatibility and easy maintenance. At Marzocchi we named our technologies in order to make them easily recognizable by the consumer and the technicians even before starting the service. All the knobs are right where you expect them to be in the proper size and the actuation is easy and intuitive and the low profile design, perfectly integrated in the shape of the crown or the lowers, makes the forks compatible with the majority of the frame designs out there. Each click performs the expected tuning setting to customize the compression and rebound to the riding style. And when it comes the time for a service the disassembly can be done using standard tools that all the bike shops use to have in the workshop. This is what we call Comfortable products.

**7 At Marzocchi  
our engineers  
care also about  
style**

In Bologna performance and products safety procedure comes together with the design to offer the most desirable suspension products on the market. Each curve, line or shape is a sort of Marzocchi trade mark that all the riders recognize without the need to look at the decals! All the products bearing the M logo are designed with style and pride.

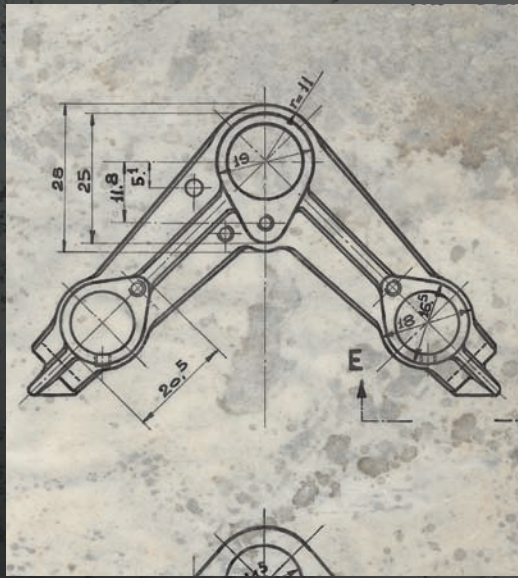

**8 At Marzocchi  
mountain bike is a  
state of mind**

All the people involved in the bike project use to say they don't work at Marzocchi, they live Marzocchi. If you ever had the chance to mess up with one of us you know what this means. It's more than a life style, it's more than a commitment, it's more than dedication, it's more than a mission. Marzocchi is our family, our life, our soul. You have to be born Marzocchi to enjoy the feeling.



# 2010 MARZOCCHI FORK LINE

CONFIDENTIAL - AM PRICE REFERENCE LIST ONLY - SUBJECT TO CHANGE					
INTENDED USE	PN	FORK SERIES	TRAVEL	FEATURES & ADJUSTMENTS	
				LEFT	RIGHT
			mm		
XC	9100201S	<b>CORSA Micro Ti Remote Control</b>	100mm	<b>TST MICRO W/ REMOTE CONTROL</b> Lock Out + Micro Adjust Compression Rebound	Air Spring Preload
XC	9100301S	<b>CORSA TST2</b>	100mm	Air Spring Preload	<b>TST2</b> Lock Out Compression Rebound
XC/AM	9100601S	<b>44 RC3 Titanium QR15 AXLE</b>	140mm	Coil Spring Preload	<b>RC3</b> Air Spring Preload Rebound HiLo Auto Compression Adjust
XC/AM	9100901S	<b>44 Micro Ti</b>	140mm (travel change to 120 by spacer supplied in the box)	<b>TST MICRO</b> Lock Out + Micro Adjust Compression Rebound	Air Spring Preload Volume Adjust
XC/AM	9100801S	<b>44 Micro Ti QR15 AXLE</b>	140mm (travel change to 120 by spacer supplied in the box)	<b>TST MICRO</b> Lock Out + Micro Adjust Compression Rebound	Air Spring Preload Volume Adjust
XC/AM	9101301S	<b>44 TST2 Air</b>	140mm (travel change to 120 by spacer supplied in the box)	Air Spring Preload	<b>TST2</b> Lock Out Compression Rebound
XC/AM	9102201S	<b>33 TST2 - USA ONLY</b>	100mm	Coil Spring Preload	<b>TST2</b> Lock Out Compression Rebound
XC/AM	9105501S	<b>33 TST2 Remote Control</b>	80mm	Coil Spring Preload	<b>TST2</b> Lock Out Compression Rebound
XC/AM	9102202S	<b>33 TST2 Remote Control</b>	100mm	Coil Spring Preload	<b>TST2</b> Lock Out Compression Rebound
XC/AM	9102101S	<b>33 TST2 Remote Control</b>	120mm	Coil Spring Preload	<b>TST2</b> Lock Out Compression Rebound
XC/AM	9102401S	<b>33 RLO</b>	100mm	Coil Spring Preload	<b>RLO</b> Lock Out Rebound
XC	9102601S	<b>22 RLO</b>	100mm	Coil Spring Preload	<b>RLO</b> Lock Out Rebound
XC	9102501S	<b>22 RLO Remote Control</b>	120mm	Coil Spring Preload	<b>RLO</b> Lock Out Rebound
TREKKING	9102701S	<b>TXC LO Remote Control</b>	60mm	<b>LO</b> Lock Out	Air Spring Preload Internal Rebound
TREKKING	9102801S	<b>TXC 1</b>	60mm	Air Spring Preload	Air Spring Preload Internal Rebound
TREKKING	9102901S	<b>TXC 2</b>	60mm	Coil Spring Preload	Air Spring Preload Internal Rebound





SPRING	CASTING	STANCHIONS	STEER TUBE	BRAKE SYSTEM		WEIGHT	COLOR
				V-BRAKE COMPATIBLE	D-BRAKE		
AIR Ti Negative Spring	32MM	NICKEL TREATMENT TAPERED	ALUMINUM	NO	6"POST MOUNT (max disc 8")	1750g remote incl.	TAIPEI GREY YS760
AIR	32MM	ALUMINUM	ALUMINUM	YES (bolts not incl.)	6"POST MOUNT (max disc 8")	2080g	WHITE YS701
1-SIDE TITANIUM	32MM QR15 AXLE	NICKEL TREATMENT TAPERED	ALUMINUM	NO	6"POST MOUNT (max disc 8")	1890g QR15 axle incl.	TAIPEI GREY YS760
AIR Ti Negative Spring	32MM	NICKEL TREATMENT TAPERED	ALUMINUM	NO	6"POST MOUNT (max disc 8")	1749g	WHITE YS701
AIR Ti Negative Spring	32MM QR15 AXLE	NICKEL TREATMENT TAPERED	ALUMINUM	NO	6"POST MOUNT (max disc 8")	1799g QR15 axle incl.	WHITE YS701
AIR	32MM	ALUMINUM	ALUMINUM	YES (bolts not incl.)	6"POST MOUNT (max disc 8")	2095g	WHITE YS701
1-SIDE COIL	32MM	TAPERED STEEL BLACK	ALUMINUM	YES (bolts not incl.)	6"POST MOUNT (max disc 8")	2327g	BLACK+GOLD YS9076
1-SIDE COIL	32MM	TAPERED STEEL BLACK	ALUMINUM	YES (bolts not incl.)	6"POST MOUNT (max disc 8")	2397g remote incl.	BLACK+GOLD YS9076
1-SIDE COIL	32MM	TAPERED STEEL BLACK	ALUMINUM	YES (bolts not incl.)	6"POST MOUNT (max disc 8")	2397g remote incl.	BLACK+GOLD YS9076
1-SIDE COIL	32MM	TAPERED STEEL BLACK	ALUMINUM	YES (bolts not incl.)	6"POST MOUNT (max disc 8")	2397g remote incl.	BLACK+GOLD YS9076
1-SIDE COIL	32MM	TAPERED STEEL BLACK	ALUMINUM	YES (bolts not incl.)	6"POST MOUNT (max disc 8")	2417g	BLACK+GOLD YS9076
1-SIDE COIL	30MM	STEEL	STEEL	YES (bolts not incl.)	6"POST MOUNT (max disc 7")	2505g	GLOSS BLACK YS728
1-SIDE COIL	30MM	STEEL	STEEL	YES (bolts not incl.)	6"POST MOUNT (max disc 7")	2575g remote incl.	GLOSS BLACK YS728
AIR	28MM	ALUMINUM	300mm ALU.	YES	INTL STD & DRUM BRAKE MOUNT	1680g	SILVER
AIR	28MM	ALUMINUM	300mm ALU.	YES	INTL STD & DRUM BRAKE MOUNT	1780g	SILVER
1-SIDE COIL	28MM	ALUMINUM	300mm STEEL	YES	INTL STD & DRUM BRAKE MOUNT	1880g	SILVER



# 2010 MARZOCCHI FORK LINE

CONFIDENTIAL - AM PRICE REFERENCE LIST ONLY - SUBJECT TO CHANGE					
INTENDED USE	PN	FORK SERIES	TRAVEL	FEATURES & ADJUSTMENTS	
			mm	LEFT	RIGHT
AM/FR	9103101S	<b>55 RC3 Titanium</b>	160mm	Coil Spring Preload	<b>RC3</b> Air Spring Preload Rebound HiLo Auto Compression Adjust
AM/FR	9103001S	<b>55 RC3 Titanium 1,5"</b>	160mm	Coil Spring Preload	<b>RC3</b> Air Spring Preload Rebound HiLo Auto Compression Adjust
AM/FR	9103301S	<b>55 Micro Air Ti</b>	160mm	<b>TST MICRO</b> Lock Out + Micro Adjust Compression Rebound	Air Spring Preload Volume Adjust
AM/FR	9105401S	<b>55 TST2 Air</b>	160mm	Air Spring Preload	<b>TST2</b> Lock Out Compression Rebound
AM/FR	9103601S	<b>55 RV</b>	160mm	<b>RV</b> Coil Spring Preload Rebound Valve	Coil Spring Preload
4X/DJ	9103801S	<b>4X RC3 20MM AXLE</b>	100mm	-	<b>RC3</b> Air Spring Preload Rebound HiLo Auto Compression Adjust
DJ	9103901S	<b>DIRT JUMPER 1 20MM AXLE</b>	100mm	-	Air Spring Preload Rebound Valve
DJ	9103902S	<b>DIRT JUMPER 1 20MM AXLE</b>	100mm	-	Air Spring Preload Rebound Valve
DJ	9104001S	<b>DIRT JUMPER 2</b>	100mm	-	Air Spring Preload Rebound Valve
DJ	9104002S	<b>DIRT JUMPER 2 20MM AXLE</b>	100mm	-	Air Spring Preload Rebound Valve
DJ	9104101S	<b>DIRT JUMPER 3</b>	100mm	-	Coil Spring Preload
XFR	9104301S	<b>66 RC3 Titanium</b>	180mm	<b>RC3</b> Rebound HiLo Auto Compression Adjust	Coil Spring Preload
XFR	9104201S	<b>66 RC3 Titanium 1,5"</b>	180mm	<b>RC3</b> Rebound HiLo Auto Compression Adjust	Coil Spring Preload
XFR	9104501S	<b>66 RC-3</b>	180mm	<b>RC3</b> Air Spring Preload Rebound HiLo Auto Compression Adjust	Coil Spring Preload
XFR	9104401S	<b>66 RC-3 1,5"</b>	180mm	<b>RC3</b> Air Spring Preload Rebound HiLo Auto Compression Adjust	Coil Spring Preload
XFR	9104701S	<b>66 RCV</b>	180mm	<b>RV</b> Air Spring Preload Rebound Valve	<b>CV</b> Coil Spring Preload Compression Valve
XFR	9104601S	<b>66 RCV 1,5"</b>	180mm	<b>RV</b> Air Spring Preload Rebound Valve	<b>CV</b> Coil Spring Preload Compression Valve
DH	9104901S	<b>888 RC-3 EVO Titanium - Ti Bolts!</b> <i>with 53mm handlebar clamp &amp; reduction shims</i>	200mm	<b>RC3 EVO</b> Rebound HiLo Auto Compression Adjust Volume Adjust	Coil Spring Preload
DH	9105101S	<b>888 RC-3 EVO</b>	200mm	<b>RC3 EVO</b> Rebound HiLo Auto Compression Adjust Volume Adjust	Coil Spring Preload
DH	9105201S	<b>888 RCV</b>	200mm	<b>RV</b> Air Spring Preload Rebound Valve	<b>CV</b> Coil Spring Preload Compression Valve



SPRING	CASTING	STANCHIONS	STEER TUBE	BRAKE SYSTEM		WEIGHT	COLOR
				V-BRAKE COMPATIBLE	D-BRAKE		
1-SIDE TITANIUM	35MM QR20 AXLE	NICKEL TREATMENT TAPERED	ALUMINUM	NO	6"POST MOUNT (max disc 8")	2410g QR20 axle incl.	TAIPEI GREY YS760
1-SIDE TITANIUM	35MM QR20 AXLE	NICKEL TREATMENT TAPERED	ALUMINUM 1,5"	NO	6"POST MOUNT (max disc 8")	2360g QR20 axle incl.	TAIPEI GREY YS760
AIR Ti Negative Spring	35MM QR20 AXLE	NICKEL TREATMENT TAPERED	ALUMINUM	NO	6"POST MOUNT (max disc 8")	2230g QR20 axle incl.	WHITE YS701
AIR	35MM QR20 AXLE	ALUMINUM	ALUMINUM	NO	6"POST MOUNT (max disc 8")	2680g QR20 axle incl.	WHITE YS701
COIL	35MM QR20 AXLE	ALUMINUM	ALUMINUM	NO	6"POST MOUNT (max disc 8")	2760g QR20 axle incl.	BLACK+GOLD YS9076
AIR	32MM+20MM AXLE	ALUMINUM	ALUMINUM	NO	6"POST MOUNT (max disc 8")	2200g 20mm axle incl.	WHITE YS701
1-SIDE COIL	32MM+20MM AXLE	ALUMINUM	ALUMINUM	NO	6"POST MOUNT (max disc 8")	2300g 20mm axle incl.	TAIPEI GREY YS760
1-SIDE COIL	32MM+20MM AXLE	ALUMINUM	ALUMINUM	NO	6"POST MOUNT (max disc 8")	2300g 20mm axle incl.	PURPLE YS750
1-SIDE COIL	32MM	STEEL	STEEL	NO	6"POST MOUNT (max disc 8")	2780g	WHITE YS701
1-SIDE COIL	32MM+20MM AXLE	STEEL	STEEL	NO	6"POST MOUNT (max disc 8")	2925g 20mm axle incl.	WHITE YS701
1-SIDE COIL	32MM	STEEL	STEEL	NO	6"POST MOUNT (max disc 8")	2700g	FLAT BLACK YS727
1-SIDE TITANIUM	38MM QR20 AXLE	NICKEL TREATMENT TAPERED	ALUMINUM	NO	8"POST MOUNT (max disc 9")	2680g QR20 axle incl.	TAIPEI GREY YS760
1-SIDE TITANIUM	38MM QR20 AXLE	NICKEL TREATMENT TAPERED	ALUMINUM 1,5"	NO	8"POST MOUNT (max disc 9")	2625g QR20 axle incl.	TAIPEI GREY YS760
1-SIDE COIL	38MM QR20 AXLE	ALUMINUM	ALUMINUM	NO	8"POST MOUNT (max disc 9")	2995g QR20 axle incl.	WHITE YS701
1-SIDE COIL	38MM QR20 AXLE	ALUMINUM	ALUMINUM 1,5"	NO	8"POST MOUNT (max disc 9")	2945g QR20 axle incl.	WHITE YS701
1-SIDE COIL	38MM QR20 AXLE	ALUMINUM	ALUMINUM	NO	8"POST MOUNT (max disc 9")	3120g QR20 axle incl.	FLAT BLACK YS727
1-SIDE COIL	38MM QR20 AXLE	ALUMINUM	ALUMINUM 1,5"	NO	8"POST MOUNT (max disc 9")	3065g QR20 axle incl.	FLAT BLACK YS727
1-SIDE TITANIUM	38MM+20MM AXLE	NICKEL TREATMENT TAPERED	ALUMINUM	NO	8"POST MOUNT (max disc 9")	2910g 20mm axle incl.	TAIPEI GREY YS760
1-SIDE COIL	38MM+20MM AXLE	ALUMINUM	ALUMINUM	NO	8"POST MOUNT (max disc 9")	3748g 20mm axle incl.	WHITE YS701
1-SIDE COIL	38MM+20MM AXLE	ALUMINUM	ALUMINUM	NO	8"POST MOUNT (max disc 9")	3688g 20mm axle incl.	FLAT BLACK YS727



# CORSA

MODEL YEAR 2010

At Marzocchi we love competition, from downhill to cross country! The specific needs are so different, but for both riding styles one thing is in common: the performance. The Corsa is specifically designed to match all the xc racers needs in terms of stiffness, hydraulic control in compression and rebound combined with an extremely efficient lock out for all models. From 80 to 100 mm of travel in order to be compatible with all frames designs front and full suspension. The Marzocchi Corsa is the ultimate cross country fork, winner of the Marathon World Championship for two years in a row in 2007 and 2008 with the Bianchi Pro Team riders Thomas Dietsch and Leonardo Paez, a prestigious success that helped to develop a full line of high end cross country weapons.

CONFIDENTIAL - AM PRICE REFERENCE LIST ONLY - SUBJECT TO CHANGE

INTENDED USE	PN	FORK SERIES	TRAVEL mm
XC	9100201S	CORSA Micro Ti Remote Control	100mm
XC	9100301S	CORSA TST2	100mm

SAMPLES: APRIL

PRODUCTION: JUNE

# SA



## REMOTE CONTROL

Ergonomic, lightweight and fast the new remote control allows to lock the fork compression control for a more efficient climb and a precise steering. As soon the terrain gets rough a small click on the top lever and you can enjoy the full travel and the famous Marzocchi plush riding to fly over the rocks. Easy to assembly the new lever is compatible with the most common shifter and levers on the market.

FEATURES & ADJUSTMENTS		SPRING	CASTING	STANCHIONS	STEER TUBE	BRAKE SYSTEM		WEIGHT	COLOR
LEFT	RIGHT		DIAMETER			V-BRAKE COMPATIBLE	D-BRAKE		
TST MICRO W/ REMOTE CONTROL Lock Out + Micro Adjust Compression Rebound	Air Spring Preload	AIR Ti Negative Spring	32MM	NICKEL TREATMENT TAPERED	ALUMINUM	NO	6"POST MOUNT (max disc 8")	1750g remote incl.	TAIPEI GREY YS760
Air Spring Preload	TST2 Lock Out Compression Rebound	AIR	32MM	ALUMINUM	ALUMINUM	YES (bolts not incl.)	6"POST MOUNT (max disc 8")	2080g	WHITE YS701

**XC**  
CROSS COUNTRY

Cross-Country: Riding along hilly trails where some bumps and smaller obstacles, such as rocks, roots, or depressions, may be encountered. Cross-Country riding does not include jumps or "drops" (riding off rocks, fallen trees or ledges) from any height. These forks must be used with tires specifically designed for cross country riding, and disk, rim or linear pull brakes.



# FOURTY

MODEL YEAR 2010

The 44 is the best representation of the all mountain concept in the Marzocchi line. As a racing tool all the components are made by precious materials like magnesium, titanium and alloy to keep the weight down! from 100 to 140mm combined with the different hydraulic cartridges in order to offer the best product for the needs of each rider and style starting from the lightweight freak with the Micro to the descent maniac that wants an RC3 cartridge and titanium spring on all his bikes from xc to dh! Yes, in 2010 Marzocchi will feature the first cross country fork with a downhill cartridge and titanium spring: low maintenance and low weight for high performance and lots of fun: your ride deserves it!



CONFIDENTIAL - AM PRICE REFERENCE LIST ONLY - SUBJECT TO CHANGE

INTENDED USE	PN	FORK SERIES	TRAVEL
			mm
XC/AM	9100601S	44 RC3 Titanium QR15 AXLE	140mm
XC/AM	9100901S	44 Micro Ti	140mm (travel change to 120 by spacer supplied in the box)
XC/AM	9100801S	44 Micro Ti QR15 AXLE	140mm (travel change to 120 by spacer supplied in the box)
XC/AM	9101301S	44 TST2 Air	140mm (travel change to 120 by spacer supplied in the box)

SAMPLES: MAY PRODUCTION: JULY

# FOUR



FEATURES & ADJUSTMENTS		SPRING	CASTING	STANCHIONS	STEER TUBE	BRAKE SYSTEM		WEIGHT	COLOR
LEFT	RIGHT		DIAMETER			V-BRAKE COMPATIBLE	D-BRAKE		
Coil Spring Preload	<b>RC3</b> Air Spring Preload Rebound HiLo Auto Compression Adjust	<b>1-SIDE TITANIUM</b>	32MM QR15 AXLE	<b>NICKEL TREATMENT TAPERED</b>	ALUMINUM	NO	6"POST MOUNT (max disc 8")	1890g QR15 axle incl.	TAIPEI GREY YS760
Lock Out + Micro Adjust Compression Rebound	Air Spring Preload Volume Adjust	<b>AIR Ti Negative Spring</b>	32MM	<b>NICKEL TREATMENT TAPERED</b>	ALUMINUM	NO	6"POST MOUNT (max disc 8")	1749g	WHITE YS701
Lock Out + Micro Adjust Compression Rebound	Air Spring Preload Volume Adjust	<b>AIR Ti Negative Spring</b>	32MM QR15 AXLE	<b>NICKEL TREATMENT TAPERED</b>	ALUMINUM	NO	6"POST MOUNT (max disc 8")	1799g QR15 axle incl.	WHITE YS701
Air Spring Preload	<b>TST2</b> Lock Out Compression Rebound	AIR	32MM	ALUMINUM	ALUMINUM	YES (bolts not incl.)	6"POST MOUNT (max disc 8")	2095g	WHITE YS701

**XC/AM**  
CROSS COUNTRY/  
ALL MOUNTAIN

This riding style is for skilled Cross Country riders, and involves moderately steep slopes and medium sized obstacles. Cross Country/All Mountain forks should be used only with rim or linear pull brakes or with disk brakes, and those frames, wheels and other components specifically designed for this riding style. The brakes must be attached to the designated mounting points provided on the fork. Never make any modification to your fork when attaching any equipment.



# FOURTY

MODEL YEAR 2010



## 44RC3 Titanium

Lighter than the first Z1 and more performing for today's all mountain riders. 32 mm stanchions, 15 mm QR axle and all the riding performance of the top open bath cartridge made by Marzocchi. A downhill fork in the all mountain chassis: the 44 RC3 is the absolute do it all fork that is light enough for fast climbing and plush and precise for breathtaking downhill.



# FOUR

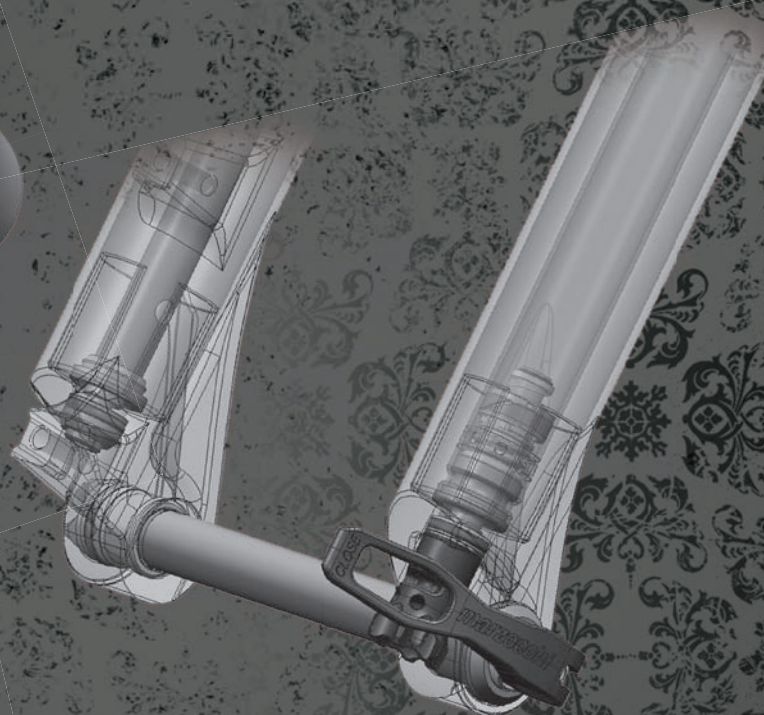

## 1.5" > 1.1/8" Tapered Aluminum steer tube (OEM ONLY)

Lighter weight and higher stiffness and strength: Easy, frame builder like Cannondale or Klein did it in the '80, a bigger diameter allows to dissipate the stress on a larger surface that can offer the same reliability as a standard tube! Stiffness increases dramatically and the tube walls can be tapered for the different intended use. This is the best way to increase steering precision and reduce weight for the best riding performance ever!

**The minimum headset length is around 115**

## QR 15

Same weight as a standard 9 mm axle system with the stiffness of a 20 mm! The QR design features all the advantage of the classic design with the steering and braking benefits of the oversized axle. Cross country goes big!



# FOURTY

MODEL YEAR 2010

Take the super versatile all mountain 44 with the super easy to use QR15 axle and slide it in a new 29" casting and you will have discover the real Marzocchi free ride soul on a twentieniner! With various travel options match your frame or your riding style from 100 to 140 mm! When we say go big, we mean it!



CONFIDENTIAL - AM PRICE REFERENCE LIST ONLY - SUBJECT TO CHANGE

INTENDED USE	PN	FORK SERIES	TRAVEL
			mm
XC/AM	9101701S	44 Micro Ti 29" QR15 AXLE - USA ONLY	120mm (travel change to 140 or 100 by spacer. 1 installed & 1 in the box)
XC/AM	9101801S	44 TST2 29" QR15 AXLE - USA ONLY	120mm (travel change to 140 or 100 by spacer. 1 installed & 1 in the box)

SAMPLES: MAY PRODUCTION: JULY

# FOUR.9



FEATURES & ADJUSTMENTS		SPRING	CASTING	STANCHIONS	STEER TUBE	BRAKE SYSTEM		WEIGHT	COLOR
LEFT	RIGHT		DIAMETER			V-BRAKE COMPATIBLE	D-BRAKE		
TST MICRO Lock Out + Micro Adjust Compression Rebound	Air Spring Preload Volume Adjust	AIR Ti Negative Spring	32MM QR15 AXLE	NICKEL TREATMENT TAPERED	ALUMINUM	NO	6"POST MOUNT (max disc 8")	1899g QR15 axle incl.	WHITE YS701
Air Spring Preload	TST2 Lock Out Compression Rebound	AIR	32MM QR15 AXLE	ALUMINUM	ALUMINUM	NO	6"POST MOUNT (max disc 8")	2250g QR15 axle incl.	BLACK+GOLD YS9076

**XC/AM**  
CROSS COUNTRY/  
ALL MOUNTAIN

This riding style is for skilled Cross Country riders, and involves moderately steep slopes and medium sized obstacles. Cross Country/All Mountain forks should be used only with rim or linear pull brakes or with disk brakes, and those frames, wheels and other components specifically designed for this riding style. The brakes must be attached to the designated mounting points provided on the fork. Never make any modification to your fork when attaching any equipment.



# THIRTY

MODEL YEAR 2010

The best thing about cycling is that each one of us can choose his own way to ride a bike. For this reason parts suppliers must offer a wide range of products in order to accomplish all the different riding needs. But what happens if the same rider uses his bike during the week for commuting and in the weekend for racing? All the components must be super versatile and extremely reliable like our 33. Three different travel options from 100 to 120, to 140 mm in order to match different frame designs and riding experience, the 33 offers the high performing chassis of the 44 with the 15 mm axle and the tapered steer tube as option, lock out and rebound control for both versions but for a pocket friendly price.



SAMPLES: APRIL

PRODUCTION: JUNE

CONFIDENTIAL - AM PRICE REFERENCE LIST ONLY - SUBJECT TO CHANGE

INTENDED USE	PN	FORK SERIES	TRAVEL mm
XC/AM	9102201S	33 TST2 - USA ONLY	100mm
XC/AM	9105501S	33 TST2 Remote Control	80mm
XC/AM	9102202S	33 TST2 Remote Control	100mm
XC/AM	9102101S	33 TST2 Remote Control	120mm

# THREE



FEATURES & ADJUSTMENTS		SPRING	CASTING	STANCHIONS	STEER TUBE	BRAKE SYSTEM		WEIGHT	COLOR
LEFT	RIGHT		DIAMETER			V-BRAKE COMPATIBLE	D-BRAKE		
Coil Spring Preload	TST2 Lock Out Compression Rebound	1-SIDE COIL	32MM	TAPERED STEEL BLACK	ALUMINUM	YES (bolts not incl.)	6"POST MOUNT (max disc 8")	2327g	BLACK+GOLD YS9076
Coil Spring Preload	TST2 Lock Out Compression Rebound	1-SIDE COIL	32MM	TAPERED STEEL BLACK	ALUMINUM	YES (bolts not incl.)	6"POST MOUNT (max disc 8")	2397g remote incl.	BLACK+GOLD YS9076
Coil Spring Preload	TST2 Lock Out Compression Rebound	1-SIDE COIL	32MM	TAPERED STEEL BLACK	ALUMINUM	YES (bolts not incl.)	6"POST MOUNT (max disc 8")	2397g remote incl.	BLACK+GOLD YS9076
Coil Spring Preload	TST2 Lock Out Compression Rebound	1-SIDE COIL	32MM	TAPERED STEEL BLACK	ALUMINUM	YES (bolts not incl.)	6"POST MOUNT (max disc 8")	2387g remote incl.	BLACK+GOLD YS9076

**XC/AM**  
**CROSS COUNTRY/  
 ALL MOUNTAIN**

This riding style is for skilled Cross Country riders, and involves moderately steep slopes and medium sized obstacles. Cross Country/All Mountain forks should be used only with rim or linear pull brakes or with disk brakes, and those frames, wheels and other components specifically designed for this riding style. The brakes must be attached to the designated mounting points provided on the fork. Never make any modification to your fork when attaching any equipment.



# TWENTY

MODEL YEAR 2010

Comfortable, this is how you feel when you ride the 22! The rebound and the preload adjusters are right there where you expect them to be and with the lock out you can control the compression while you are climbing the hills. The new 22 offers all the riding fun of a competition fork for the price of an entry level. 100 or 120 mm of pure Marzocchi feeling that will make feel at home on any trail you want to ride.



CONFIDENTIAL - AM PRICE REFERENCE LIST ONLY - SUBJECT TO CHANGE

INTENDED USE	PN	FORK SERIES	TRAVEL mm
XC	9102601S	22 RLO	100mm
XC	9102501S	22 RLO Remote Control	120mm

SAMPLES: APRIL

PRODUCTION: JUNE

# TWO



FEATURES & ADJUSTMENTS		SPRING	CASTING	STANCHIONS	STEER TUBE	BRAKE SYSTEM		WEIGHT	COLOR
LEFT	RIGHT		DIAMETER			V-BRAKE COMPATIBLE	D-BRAKE		
Coil Spring Preload	LOCK Lock Out Rebound	1-SIDE COIL	30MM	STEEL	STEEL	YES (bolts not incl.)	6"POST MOUNT (max disc 7")	2505g	GLOSS BLACK YS728
Coil Spring Preload	LOCK Lock Out Rebound	1-SIDE COIL	30MM	STEEL	STEEL	YES (bolts not incl.)	6"POST MOUNT (max disc 7")	2575g remote incl.	GLOSS BLACK YS728

## XC CROSS COUNTRY

Cross-Country: Riding along hilly trails where some bumps and smaller obstacles, such as rocks, roots, or depressions, may be encountered. Cross-Country riding does not include jumps or "drops" (riding off rocks, fallen trees or ledges) from any height. These forks must be used with tires specifically designed for cross country riding, and disk, rim or linear pull brakes.



# TREKK

## MODEL YEAR 2010

When it comes about trekking bikes the needs and the expectations on suspension are increasing! Some use their bike to commute daily from home to the office, some other to train, others to travel from coast to coast. Front suspensions need to offer comfort and steering precision on one side and all kind of mounting points for generators, racks and fenders on the other. The versatile TXC line features all of this, combined with the premium Marzocchi plush feeling for a comfortable ride on light off road tours or on fast and high rolling asphalt roads.

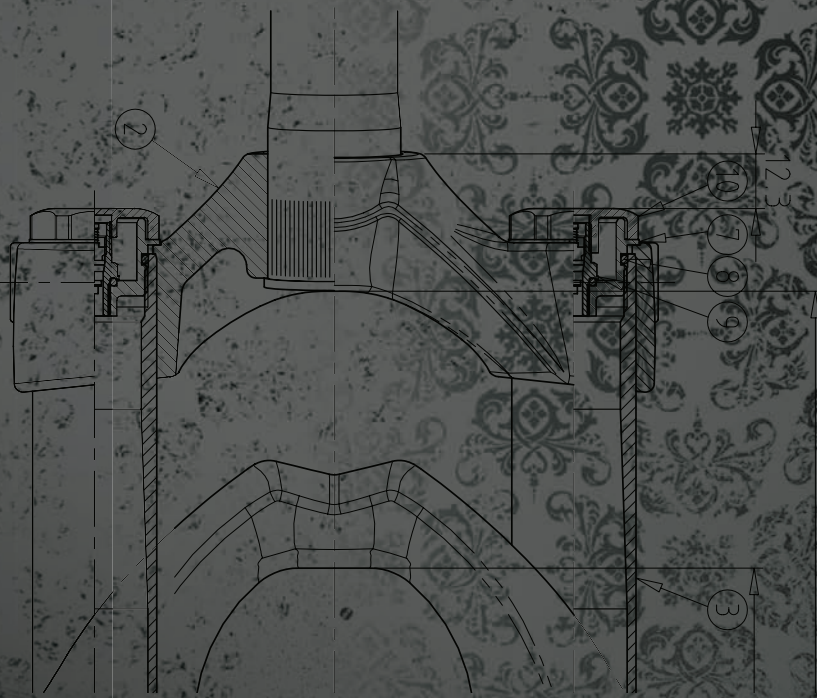

CONFIDENTIAL - AM PRICE REFERENCE LIST ONLY - SUBJECT TO CHANGE

INTENDED USE	PN	FORK SERIES	TRAVEL mm
TREKKING	9102701S	TXC LO Remote Control	60mm
TREKKING	9102801S	TXC 1	60mm
TREKKING	9102901S	TXC 2	60mm

SAMPLES: APRIL

PRODUCTION: JUNE



# ING



FEATURES & ADJUSTMENTS		SPRING	CASTING	STANCHIONS	STEER TUBE	BRAKE SYSTEM		WEIGHT	COLOR
LEFT	RIGHT		DIAMETER			V-BRAKE COMPATIBLE	D-BRAKE		
LO Lock Out	Air Spring Preload Internal Rebound	AIR	28MM	ALUMINUM	300mm ALU.	YES	INTL STD & DRUM BRAKE MOUNT	1680g	SILVER
Air Spring Preload	Air Spring Preload Internal Rebound	AIR	28MM	ALUMINUM	300mm ALU.	YES	INTL STD & DRUM BRAKE MOUNT	1780g	SILVER
Coil Spring Preload	Air Spring Preload Internal Rebound	1-SIDE COIL	28MM	ALUMINUM	300mm STEEL	YES	INTL STD & DRUM BRAKE MOUNT	1880g	SILVER

**TXC**  
TREKKING

Riding along asphalt and hilly trails where some bumps and smaller obstacles, such as rocks, roots, or depressions, may be encountered. Trekking riding does not include jumps or "drops" (riding off rocks, fallen trees or ledges) from any height. These forks must be used with tires specifically designed for trekking riding, and disk, rim or linear pull brakes. You should only attach generators and racks, if any, to the designated mounting points provided on the forks.



# FIFTY

MODEL YEAR 2010

In just two years the 55 achieved the goal to become the ultimate all rounder, the queen of Enduro races, the real and only fork that could take the place of the Z1. Pro rider loves this fork, light enough to climb any mountain, strong enough to survive any abuse, stiff to run over all the rocks and roots, plush to make you feel comfortable on any trail. Air or coil to accomplish the riding feeling you prefer combined with the famous Marzocchi hydraulic systems for the smoothest ride you ever had.



CONFIDENTIAL - AM PRICE REFERENCE LIST ONLY - SUBJECT TO CHANGE

INTENDED USE	PN	FORK SERIES	TRAVEL mm
AM/FR	9103101S	55 RC3 Titanium	160mm
AM/FR	9103001S	55 RC3 Titanium 1.5"	160mm
AM/FR	9103301S	55 Micro Air Ti	160mm
AM/FR	9105401S	55 TST2 Air	160mm
AM/FR	9103601S	55 RV	160mm

SAMPLES: MAY PRODUCTION: JULY

# FIVE



FEATURES & ADJUSTMENTS		SPRING	CASTING	STANCHIONS	STEER TUBE	BRAKE SYSTEM		WEIGHT	COLOR
LEFT	RIGHT		DIAMETER			V-BRAKE COMPATIBLE	D-BRAKE		
Coil Spring Preload	Air Spring Preload Rebound RC3 HiLo Auto Compression Adjust	1-SIDE TITANIUM	35MM QR20 AXLE	NICKEL TREATMENT TAPERED	ALUMINUM	NO	6"POST MOUNT (max disc 8")	2410g QR20 axle incl.	TAIPEI GREY YS760
Coil Spring Preload	Air Spring Preload Rebound RC3 HiLo Auto Compression Adjust	1-SIDE TITANIUM	35MM QR20 AXLE	NICKEL TREATMENT TAPERED	ALUMINUM 1.5"	NO	6"POST MOUNT (max disc 8")	2360g QR20 axle incl.	TAIPEI GREY YS760
TST MICRO Lock Out + Micro Adjust Compression Rebound	Air Spring Preload Volume Adjust	AIR Ti Negative Spring	35MM QR20 AXLE	NICKEL TREATMENT TAPERED	ALUMINUM	NO	6"POST MOUNT (max disc 8")	2230g QR20 axle incl.	WHITE YS701
Air Spring Preload	TST2 Lock Out Compression Rebound	AIR	35MM QR20 AXLE	ALUMINUM	ALUMINUM	NO	6"POST MOUNT (max disc 8")	2680g QR20 axle incl.	WHITE YS701
RV Coil Spring Preload Rebound Valve	Coil Spring Preload	COIL	35MM QR20 AXLE	ALUMINUM	ALUMINUM	NO	6"POST MOUNT (max disc 8")	2760g QR20 axle incl.	BLACK+GOLD YS9076

**AM/FR**  
ALL MOUNTAIN/  
FREERIDE

All Mountain/Freeride: This riding style is for skilled riders, and involves steep, aggressive slopes, large obstacles, and moderate jumps. Freeride forks should be used only with disk brakes, and those frames, wheels and other components specifically designed for this riding style. The disk brakes must be attached to the designated mounting points provided on the fork. Never make any modification to your fork when attaching any equipment.



# FIFTY

MODEL YEAR 2010

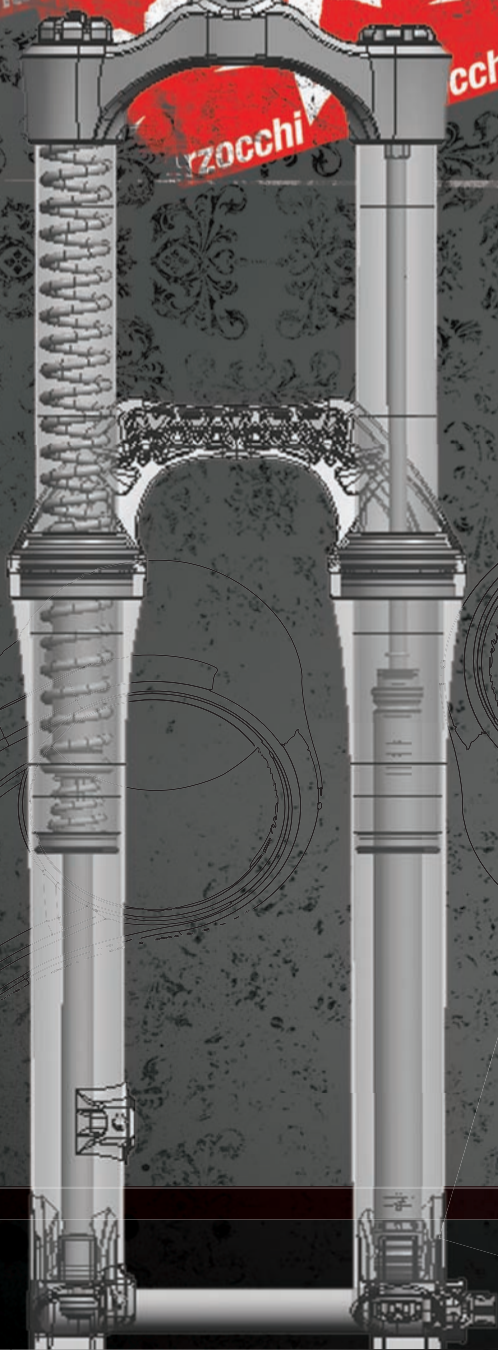

## NEW QR20 AXLE AND 12MM REAR AXLE

There is no better oversized QR system out there than the one we designed for the 44! Easy and friendly to use that you wouldn't really notice the difference between a 9 mm! We are so confident about this system that we had to redesign our 20 mm quick release too! The result is so amazing that it inspired the Marzocchi engineers for a 12 mm rear axle. The result is a consistent design line between front and rear drivetrain that shows the care in all the details. The 20 mm QR is compatible with all the 55 and 66 castings like the rear axle matches the patented 12 mm frame design standard.

# FIVE

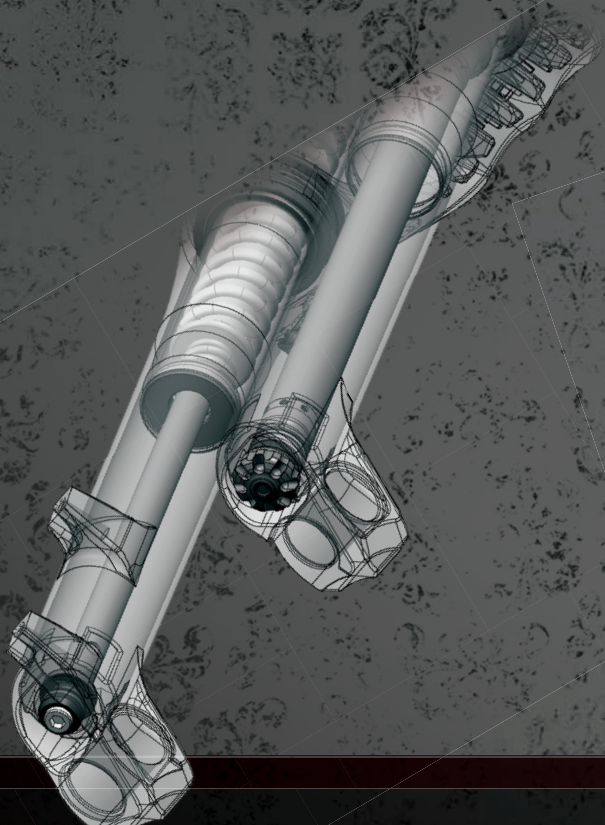

## 55RC3 TITANIUM

The Z1 is Back! RC3 downhill open bath cartridge to accomplish all the riding fun you want with the plus of the plush feeling of the coil spring. High and low speed compression control to keep your tire glued to the trail with the steering precision of the new 20 mm QR axle system



## 1.5" > 1.1/8" Tapered Aluminum steer tube (OEM ONLY)

Lighter weight and higher stiffness and strength: Easy, frame builder like Cannondale or Klein did it in the '80, a bigger diameter allows to dissipate the stress on a larger surface that can offer the same reliability as a standard tube! Stiffness increases dramatically and the tube walls can be tapered for the different intended use. This is the best way to increase steering precision and reduce weight for the best riding performance ever!

The minimum headtube length is around 115



# FOUR

MODEL YEAR 2010

In the 4X discipline it takes a few seconds to play your game. The rider coming first out from the first corner has the best chance to win the battle. All the components must perform at the best. A standard DJ is for some guys like Brian Lopes, Cedric Gracia or Guido Tschugg not enough, so we must took the DJ chassis and we pimp it up with lightweight black anodized stanchion tubes and a super reliable air system. In the right leg we put our popular open bath downhill cartridge RC3 to control rebound and compression like on a Triple Eight. The new lowers with the 20 mm bolt on through axle and the oversized crown are the best guarantee for unbeatable stiffness and steering precision.



CONFIDENTIAL - AM PRICE REFERENCE LIST ONLY - SUBJECT TO CHANGE

INTENDED USE	PN	FORK SERIES	TRAVEL	FEA
			mm	LEFT
4X/DJ	9103801S	4X RC3 20MM AXLE	100mm	-

SAMPLES: APRIL

PRODUCTION: JUNE

# CROSS



FEATURES & ADJUSTMENTS	SPRING	CASTING DIAMETER	STANCHIONS	STEER TUBE	BRAKE SYSTEM		WEIGHT	COLOR
					V-BRAKE COMPATIBLE	D-BRAKE		
RIGHT (PCS) Air Spring Preload Rebound HiLo Auto Compression Adjust	AIR	32MM+20MM AXLE	ALUMINUM	ALUMINUM	NO	6"POST MOUNT (max disc 8")	2200g 20mm axle incl.	WHITE YS701

## 4X/DJ FOURCROSS DIRTJUMPING

4X/Dirt Jumping: This "BMX" or "motocross" style of riding is only for the most skilled riders, and involves jumping from one mound of dirt to another. It also includes riding over and around "urban obstacles" such as man-made, or other concrete, structures, or racing on a track consisting of jumps made from mounds of dirt which the rider must negotiate by jumping or turning at speed. These forks should only be used with disk brakes, and those frames, wheels and other components specifically designed for this riding style. The disk brakes must be attached to the designated mounting points provided on the fork. Never make any modification to your fork when attaching any equipment.





# DIRT

MODEL YEAR 2010

Dirt Jumping is not only a sport, is not only a discipline, is not only a state of mind. Dirt Jumping is all this together. A sort of disease that can be diagnosed by an incredible seek of air. The cure? Just fly higher! For 2010 the Marzocchi bestseller has been redesigned in and out side. Stronger, cooler and more performing then ever! New lowers and crown to survive all the most radical Events all over the world or the daily urban attack! To control all this power inside the right leg is hidden a new open bath rebound valve that will make the landing as smooth as the flight.



SAMPLES: APRIL

PRODUCTION: JUNE

CONFIDENTIAL - AM PRICE REFERENCE LIST ONLY - SUBJECT TO CHANGE

INTENDED USE	PN	FORK SERIES	TRAVEL
			mm
DJ	9103901S	DIRT JUMPER 1 20MM AXLE	100mm
DJ	9103902S	DIRT JUMPER 1 20MM AXLE	100mm
DJ	9104001S	DIRT JUMPER 2	100mm
DJ	9104002S	DIRT JUMPER 2 20MM AXLE	100mm
DJ	9104101S	DIRT JUMPER 3	100mm



# JUMPER



FEATURES & ADJUSTMENTS		SPRING	CASTING	STANCHIONS	STEER TUBE	BRAKE SYSTEM		WEIGHT	COLOR
LEFT	RIGHT		DIAMETER			V-BRAKE COMPATIBLE	D-BRAKE		
	Air Spring Preload Rebound Valve	1-SIDE COIL	32MM+20MM AXLE	ALUMINUM	ALUMINUM	NO	6"POST MOUNT (max disc 8")	2300g 20mm axle incl.	TAIPEI GREY YS760
	Air Spring Preload Rebound Valve	1-SIDE COIL	32MM+20MM AXLE	ALUMINUM	ALUMINUM	NO	6"POST MOUNT (max disc 8")	2300g 20mm axle incl.	PURPLE YS760
	Air Spring Preload Rebound Valve	1-SIDE COIL	32MM	STEEL	STEEL	NO	6"POST MOUNT (max disc 8")	2780g	WHITE YS701
	Air Spring Preload Rebound Valve	1-SIDE COIL	32MM+20MM AXLE	STEEL	STEEL	NO	6"POST MOUNT (max disc 8")	2925g 20mm axle incl.	WHITE YS701
	Coil Spring Preload	1-SIDE COIL	32MM	STEEL	STEEL	NO	6"POST MOUNT (max disc 8")	2700g	FLAT BLACK YS727

**4X/DJ**  
FOURCROSS  
DIRTJUMPING

4X/Dirt Jumping: This "BMX" or "motocross" style of riding is only for the most skilled riders, and involves jumping from one mound of dirt to another. It also includes riding over and around "urban obstacles" such as man-made, or other concrete, structures, or racing on a track consisting of jumps made from mounds of dirt which the rider must negotiate by jumping or turning at speed. These forks should only be used with disk brakes, and those frames, wheels and other components specifically designed for this riding style. The disk brakes must be attached to the designated mounting points provided on the fork. Never make any modification to your fork when attaching any equipment.



# SIXTY

MODEL YEAR 2010

Many forks in the Marzocchi production made history, but the 66 is a milestone on it self! Since the company presented the first 66 it was clear that size matters. For 2010 the Queen of the single crown free ride forks will feature the new 20 mm QR axle combined with the stiffest and precise lowers and 38 mm stanchions tubes that Marzocchi ever made, performing 180 mm of plush travel for all versions. Air or coil spring are matched with the well known RC3 cartridge or the revisited edition of our popular open bath RCV hydraulic control.



CONFIDENTIAL - AM PRICE REFERENCE LIST ONLY - SUBJECT TO CHANGE

INTENDED USE	PN	FORK SERIES	TRAVEL mm
XFR	9104301S	66 RC3 Titanium	180mm
XFR	9104201S	66 RC3 Titanium 1.5"	180mm
XFR	9104501S	66 RC-3	180mm
XFR	9104401S	66 RC-3 1.5"	180mm
XFR	9104701S	66 RCV	180mm
XFR	9104601S	66 RCV 1.5"	180mm

SAMPLES: APRIL

PRODUCTION: JUNE

# SIX



## QR 20 MM AXLE

There is no better oversized QR system out there than the one we designed for the 44! Easy and friendly to use that you wouldn't really notice the difference between a 9 mm! We are so confident about this system that we had to redesign our 20 mm quick release too! The 20 mm QR is compatible with all the 55 and 66 castings.

FEATURES & ADJUSTMENTS		SPRING	CASTING	STANCHIONS	STEER TUBE	BRAKE SYSTEM		WEIGHT	COLOR
LEFT	RIGHT		DIAMETER			V-BRAKE COMPATIBLE	D-BRAKE (MAX DISC 9")		
RC3 Rebound HiLo Auto Compression Adjust	Coil Spring Preload	1-SIDE TITANIUM	38MM QR20 AXLE	NICKEL TREATMENT TAPERED	ALUMINUM	NO	8"POST MOUNT (max disc 9")	2680g QR20 axle incl.	TAIPEI GREY YS760
RC3 Rebound HiLo Auto Compression Adjust	Coil Spring Preload	1-SIDE TITANIUM	38MM QR20 AXLE	NICKEL TREATMENT TAPERED	ALUMINUM 1.5"	NO	8"POST MOUNT (max disc 9")	2625g QR20 axle incl.	TAIPEI GREY YS760
RC3 Air Spring Preload Rebound HiLo Auto Compression Adjust	Coil Spring Preload	1-SIDE COIL	38MM QR20 AXLE	ALUMINUM	ALUMINUM	NO	8"POST MOUNT (max disc 9")	2995g QR20 axle incl.	WHITE YS701
RC3 Air Spring Preload Rebound HiLo Auto Compression Adjust	Coil Spring Preload	1-SIDE COIL	38MM QR20 AXLE	ALUMINUM	ALUMINUM 1.5"	NO	8"POST MOUNT (max disc 9")	2945g QR20 axle incl.	WHITE YS701
RV Air Spring Preload Rebound Valve	CV Coil Spring Preload Compression Valve	1-SIDE COIL	38MM QR20 AXLE	ALUMINUM	ALUMINUM	NO	8"POST MOUNT (max disc 9")	3120g QR20 axle incl.	FLAT BLACK YS727
RV Air Spring Preload Rebound Valve	CV Coil Spring Preload Compression Valve	1-SIDE COIL	38MM QR20 AXLE	ALUMINUM	ALUMINUM 1.5"	NO	8"POST MOUNT (max disc 9")	3065g QR20 axle incl.	FLAT BLACK YS727

**XFR/DH**  
EXTREME  
FREERIDE/  
DOWNHILL

Extreme Freeride/Downhill: This discipline is only for professional or highly skilled riders. It includes relatively high jumps or "drops" and negotiating larger obstacles such as boulders, fallen trees, or holes. These forks should be used only with disk brakes, and those frames, wheels and other components specifically designed for this riding style. The disk brakes must be attached to the designated mounting points provided on the fork. Never make any modification to your fork when attaching other equipment.





# TRIPLE

MODEL YEAR 2010

Are you ready to scramble your notion of "fast" and redefine it forever? Ride the Evo! A new generation of 888 that allows you to tune the compression curve like you dreamed for decades! The only fork line that fits the needs of the top Pro's and the free rider. All the 2010 Triple Eights represents the ultimate motorcycle hydraulic technology applied on mountain bike forks to perform the most complete riding experience. The new benchmark for double crown forks is born, now it's up to you!

CONFIDENTIAL - AM PRICE REFERENCE LIST ONLY - SUBJECT TO CHANGE

INTENDED USE	PN	FORK SERIES	TRAVEL mm
DH	9104901S	888 RC-3 EVO Titanium - Ti Bolts! <i>with 53mm handlebar clamp &amp; reduction shims</i>	200mm
DH	9105101S	888 RC-3 EVO	200mm
DH	9105201S	888 RCV	200mm

SAMPLES: MAY PRODUCTION: JULY

# EIGHT



FEATURES & ADJUSTMENTS		SPRING	CASTING	STANCHIONS	STEER TUBE	BRAKE SYSTEM		WEIGHT	COLOR
LEFT	RIGHT		DIAMETER			V-BRAKE COMPATIBLE	D-BRAKE		
<b>RC3 EVO</b> Rebound HiLo Auto Compression Adjust Volume Adjust	Coil Spring Preload	1-SIDE TITANIUM	38MM+20MM AXLE	NICKEL TREATMENT TAPERED	ALUMINUM	NO	8"POST MOUNT (max disc 9")	2910g 20mm axle incl.	TAIPEI GREY YS760
<b>RC3 EVO</b> Rebound HiLo Auto Compression Adjust Volume Adjust	Coil Spring Preload	1-SIDE COIL	38MM+20MM AXLE	ALUMINUM	ALUMINUM	NO	8"POST MOUNT (max disc 9")	3748g 20mm axle incl.	WHITE YS701
<b>RV</b> Air Spring Preload Rebound Valve	<b>CV</b> Coil Spring Preload Compression Valve	1-SIDE COIL	38MM+20MM AXLE	ALUMINUM	ALUMINUM	NO	8"POST MOUNT (max disc 9")	3688g 20mm axle incl.	FLAT BLACK YS727

**XFR/DH**  
**EXTREME**  
**FREERIDE/**  
**DOWNHILL**

Extreme Freeride/Downhill: This discipline is only for professional or highly skilled riders. It includes relatively high jumps or "drops" and negotiating larger obstacles such as boulders, fallen trees, or holes. These forks should be used only with disk brakes, and those frames, wheels and other components specifically designed for this riding style. The disk brakes must be attached to the designated mounting points provided on the fork. Never make any modification to your fork when attaching other equipment.



# TRIPLE

MODEL YEAR 2010



## RC3 CARTRIDGE

Some times is hard to decide if the product should be designed to suit the Pro riders need or the average mountain biker. So we decided to let the rider decide. Our revolutionary RC3 open bath cartridge is the first serviceable an with an interchangeable compression shims set to accomplish all your needs. Developed with the precious help of our Pro riders we achieved the goal to perfectly tune the same fork for Thomas Vanderham or Wade Simmons and Richie Schley and Rob J. All this riders knows how to bring the bike to the limit but they all have different riding style and weights! There is no magic and no secret, it's motorcycle industry tuning procedure! Now, would you go to the mall with a F1 Ferrari? Or would you race Valentino Rossi with a Vespa? Now you can!

# EIGHT

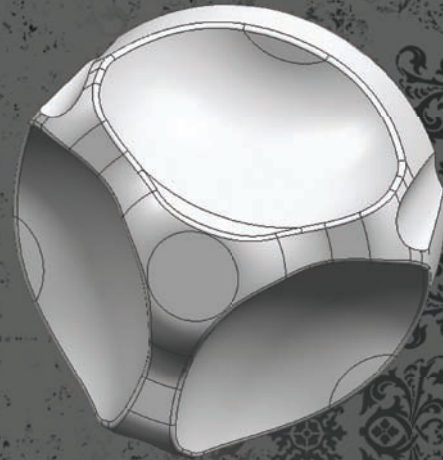

## TAPERED STANCHIONS

To make the World Cup a real World Cup prof fork we had to make the Triple Eight loose some weight! Stiffness, steering precision and reliability had to remain the same. The solution? We took almost 300 grams off by machining the stanchion tubes! The nickel coating keeps the tubes strong and durable and the overall riding pleasure increases thanks to the better weight-performance ratio.

## RC3 COMPRESSION KNOB



# DECALS

MODEL YEAR 2010







MARZOCCHI PREMIUM SUSPENSION

# BOMBER



MARZOCCHI PREMIUM SUSPENSION

# BOMBER



# DECALS

MODEL YEAR 2010





MARZOCCHI PREMIUM SUSPENSION

# BOMBER

44  
MICRO TI

MARZOCCHI PREMIUM SUSPENSION

# BOMBER

44  
MICRO TI



# DECALS

MODEL YEAR 2010





# DECALS

MODEL YEAR 2010

BOMBER



BOMBER





**BONBER**



**BONBER**



# DECALS

MODEL YEAR 2010





## 2010 MARZOCCHI OFFSET CHART

	STROKE (S)	CROWN-AXLE DISTANCE (F) ±5mm	AXLE OFFSET (D)	CROWN OFFSET (B)	CROWN WIDTH (G)	UPPER/LOWER CROWN (H)
CORSA Micro Ti	100	472	26	18	170	-
CORSA TST2	100	477.5	26	18	170	-
44 RC3 Titanium	140	514	26	18	170	-
44 Micro Ti	120	492	26	18	170	-
44 Micro Ti	140	512	26	18	170	-
44 TST2 Air	120	495	26	18	170	-
44 TST2 Air	140	515	26	18	170	-
44 Micro Ti 29"	100	507	26	18	170	-
44 Micro Ti 29"	120	527	26	18	170	-
44 Micro Ti 29"	140	547	26	18	170	-
44 TST2 29"	100	510	26	18	170	-
44 TST2 29"	120	530	26	18	170	-
44 TST2 29"	140	550	26	18	170	-
33 TST2	80	458	26	18	170	-
33 TST2	100	478	26	18	170	-
33 TST2	120	498	26	18	170	-
33 TST2	140	518	26	18	170	-
33 RLO	100	478	26	18	170	-
22 RLO	100	492	26	18	170	-
22 RLO	120	512	26	18	170	-
TXC LO	60	466	0	34.5	150	-
TXC 1	60	466	0	34.5	150	-
TXC 2	60	466	0	34.5	150	-
55 RC3 Titanium	160	548	26	18	180	-
55 Micro Air Ti	160	548	26	18	180	-
55 TST2 Air	160	546	26	18	180	-
55 RV	160	549	26	18	180	-
4X RC3	100	477.5	30	18	170	-
DIRT JUMPER 1	100	477.5	30	18	170	-
DIRT JUMPER 2	100	477.5	30	18	170	-
DIRT JUMPER 3	100	477.5	30	18	170	-
66 RC3 Titanium	180	568	32	14	201	-
66 RC-3	180	568	32	14	201	-
66 RCV	180	568	32	14	201	-
888 RC-3 EVO Titanium	200	583	32	14	196	169
888 RC-3 EVO	200	583	32	14	196	169
888 RCV	200	583	32	14	196	169

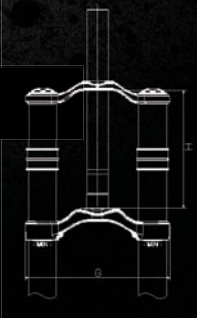

# ROCCO

## REAR SUSPENSION

MODEL YEAR 2010

### WATCH YOUR BACK!

The evolution of the mountain bike as a sport is strictly related with the one of the rear shocks. The extended use of suspension allowed the frame designers to bypass many technical limits of the hard tails and to ensure more fun and increase safety. When full suspension bikes became popular the shocks helped the designer once again thanks to pedal platform valves solving unpleasant issues like pedal bobbing and leak of traction. Now that frames and shocks reached the top of evolution consumers are requesting more intuitive to use products without losing the achieved performance level. This is exactly what inspired the new generation of Marzocchi rear shocks. Starting from the World Cup version, the LO or the TST all our rear suspension are easy to build, easy to tune and to maintain! Nickel coated air chambers and low friction seals are the best guarantee for a stiction free and smooth ride on any trail and if you want to have the perfect ride each time you go, match the shock with a Marzocchi fork so you will have the front suspension working simultaneously with the rear keeping your tires always on the trail while you fly over the rocks.

## 2010 SHOCK LINE

CONFIDENTIAL - PRELIMINARY OEM SPECS LISTS - SUBJECT TO CHANGE

MODEL	Features	Sizes		Weight
		in.	mm	
<b>ROCO RC World Cup Coil w/ Piggyback</b>	Externally adjustable High Speed Compression Externally adjustable Rebound Externally adjustable bottom-out resistance via air valve. Spring preload	9.5 x 3.0" 8.75 x 2.75" 8.5 x 2.5"	241.3 x 76.2mm 222 x 70mm 215.5 x 63.5mm	length 200 & spring 400 815g
<b>ROCO TST R Coil w/ Piggyback</b>	Externally adjustable Trail Selection Tecology (TST) Externally Adjustable Rebound Externally Adjustable bottom-out via air valve. Spring preload	8.75 x 2.75" 8.5 x 2.5" 7.88 x 2.25"	222 x 70mm 215.5 x 63.5mm 200 x 57mm	length 200 & spring 400 815g
<b>ROCO AIR RC WORLD CUP Air w/ Piggyback</b>	Externally adjustable High Speed Compression Externally adjustable Rebound Externally adjustable bottom-out resistance via air valve. Adjustable Air Spring - High Volume Linear Air Spring Nickel coated Air Cannister  <i>Carbon fiber layer around external air chamber for lighter weight</i>	9.5 x 3.0" 8.75 x 2.75" 8.5 x 2.5"	241.3 x 76.2mm 222 x 70mm 215.5 x 63.5mm	length 190 455g
<b>ROCO AIR TST R Air w/ Piggyback</b>	Externally adjustable Trail Selection Tecology (TST) Externally Adjustable Rebound Externally Adjustable bottom-out via air valve. Adjustable Air Spring - High Volume Linear Air Spring Nickel coated Air Cannister  <i>Carbon fiber layer around external air chamber for lighter weight</i>	8.5 x 2.5" 7.88 x 2.25" 8.74 x 2.75"	215.5 x 63.5mm 200 x 57mm 222 x 70mm	length 190 455g
<b>ROCO LO Air in-line</b>	Lock Out Adjustable Air Spring - High Volume Linear Air Spring Nickel coated Air Cannister External Rebound Adjustment <i>Carbon fiber layer around external air chamber for lighter weight from length 190</i>	7.88 x 2.25" 7.88 x 2.0" 7.5 x 2.0" 6.5 x 1.5"	<i>200 x 57mm 200 x 50mm 190.5 x 50mm</i> 165.1 x 38.1mm	length 152 255g  <i>carbon fiber chamber +29g</i>



# ROCO

## WORLD CUP

### MODEL YEAR 2010

What makes a rear shock Word Cup suitable? The way you can customize the performance to your riding style! The Marzocchi World Cup line offers the widest compression and rebound tuning range on the market! Each click makes you perceive the tuning difference and brings you one step ahead to your perfect setup. Combining the high speed compression, the bottom-out resistance via air valve and the spring preload the Roco rear shocks can match all the frame designs, all the riding style and all the riders expectations.

CONFIDENTIAL - PRELIMINARY OEM SPECS LISTS - SUBJECT TO CHANGE

MODEL	Features	Sizes		Weight
		in.	mm	
<b>ROCO RC World Cup</b> <i>Coil w/ Piggyback</i>	Externally adjustable High Speed Compression Externally adjustable Rebound Externally adjustable bottom-out resistance via air valve. Spring preload	9.5 x 3.0" 8.75 x 2.75" 8.5 x 2.5"	241.3 x 76.2mm 222 x 70mm 215.5 x 63.5mm	<i>length 200 &amp; spring 400</i> 815g
<b>ROCO AIR RC WORLD CUP</b> <i>Air w/ Piggyback</i>	Externally adjustable High Speed Compression Externally adjustable Rebound Externally adjustable bottom-out resistance via air valve. Adjustable Air Spring - High Volume Linear Air Spring Nickel coated Air Cannister  <i>Carbon fiber layer around external air chamber for lighter weight</i>	9.5 x 3.0" 8.75 x 2.75" 8.5 x 2.5"	241.3 x 76.2mm 222 x 70mm 215.5 x 63.5mm	<i>length 190</i> 455g



**ROCO RC WORLD CUP**



**ROCO AIR WORLD CUP**



# ROCO

## TST

MODEL YEAR 2010

Same compression tuning range as the World Cup shock but the 24 clicks are all available in a 180° rotating knob. The easiest way to go from fully open to a full compression controlled rear end that guarantees a good comfort level on small bumps. It's not a lock out, it's not a pedal platform... It's TST, the Marzocchi exclusive premium compression control that makes your bike fly over the rocks while your tires stick to the ground!

**CONFIDENTIAL - PRELIMINARY OEM SPECS LISTS - SUBJECT TO CHANGE**

MODEL	Features	Sizes		Weight
		in.	mm	
<b>ROCO TST R</b> <i>Coil w/ Piggyback</i>	Externally adjustable Trail Selection Technology (TST) Externally Adjustable Rebound Externally Adjustable bottom-out via air valve. Spring preload	8.75 x 2.75" 8.5 x 2.5" 7.88 x 2.25"	222 x 70mm 215.5 x 63.5mm 200 x 57mm	<i>length 200 &amp; spring 400</i> 815g
<b>ROCO AIR TST R</b> <i>Air w/ Piggyback</i>	Externally adjustable Trail Selection Technology (TST) Externally Adjustable Rebound Externally Adjustable bottom-out via air valve. Adjustable Air Spring - High Volume Linear Air Spring Nickel coated Air Cannister  <i>Carbon fiber layer around external air chamber for lighter weight</i>	8.5 x 2.5" 7.88 x 2.25" 8.74 x 2.75"	215.5 x 63.5mm 200 x 57mm 222 x 70mm	<i>length 190</i> 455g



**ROCO TST R**



**ROCO AIR TST R**



# ROCO LO

When cross country riders move to a fully suspended frame they want the comfort, but sometimes they are not willing to accept the price. So we designed the perfect rear shock that gives to the bike frame the acceleration of a hard tail and the comfort of a coil spring. The Marzocchi lock out system is the most efficient device to make the bike react like a trigger and the special dual chamber design gives to the air spring enough room to imitate the compression curve of a coil spring. All in one!

CONFIDENTIAL - PRELIMINARY OEM SPECS LISTS - SUBJECT TO CHANGE

MODEL	Features	Sizes		Weight
		in.	mm	
<b>ROCO LO</b> <i>Air in-line</i>	Lock Out Adjustable Air Spring - High Volume Linear Air Spring Nickel coated Air Cannister External Rebound Adjustment <i>Carbon fiber layer around external air chamber for lighter weight from length 190</i>	7.88 x 2.25" 7.88 x 2.0" 7.5 x 2.0" 6.5 x 1.5"	200 x 57mm 200 x 50mm 190.5 x 50mm 165.1 x 38.1mm	length 152 255g  <i>carbon fiber chamber            +29g</i>



marzocchi marzocchi marzocchi marzocchi marzocchi marzocchi marzocchi marzocchi marzocchi marzocchi



**ROCO LO DUAL CHAMBER**



**ROCO LO SINGLE CHAMBER**



# DISTRIBUTORS

## MARZOCCHI USA

25213 Anza Drive - VALENCIA - CA 91355 USA  
- USA

**Phone:** +1 661 257 6630

**Fax:** +1 661 257 6636

**E-mail:** marzmail@marzocchiusa.com

**Web site:** <http://www.marzocchi.com>

**Distributor for:** Anguilla, Antigua And Barbuda, Netherlands Antilles, Argentina, Aruba, Bahamas, The, Barbados, Bermuda, Bolivia, Chile, Colombia, Cuba, Ecuador, Jamaica, Grenada, Guadeloupe, French Guiana, Guyana, Haiti, Martinique, Montserrat, Paraguay, Peru, Puerto Rico, Dominican Republic, USA, Suriname, Trinidad And Tobago, Uruguay, Venezuela

## MARZOCCHI.COM SRL

Via Poli, 5a - 40069 - Zola Predosa (Bologna)  
- Italy

**Phone:** +39 051 6168737

**Fax:** +39 051 7459504

**E-mail:** [info@marzocchi.com](mailto:info@marzocchi.com)

**Web site:** <http://www.marzocchi.com>

**Distributor for:** Italy, Sweden

## MARZOCCHI CANADA (SERVICE CENTER ONLY)

1450 Rupert Street - North Vancouver, BC V7J  
1E9 - Canada

**Phone:** +1 604 986 3675

**Fax:** +1 604 986 3675

**E-mail:** [naze@marzocchicanada.com](mailto:naze@marzocchicanada.com)

**Web site:** <http://www.marzocchicanada.com>

**Distributor for:** Canada

## SESSIONS BRASIL

R. Padre Meliton Vigueira Penillos, 132 - Cep  
- 05305-070 - V. Leopoldina - Sao Paulo - SP  
- Brazil

**Phone:** 55-11-3831-3100

**E-mail:** [contato@3smultidistribuidora.com.br](mailto:contato@3smultidistribuidora.com.br)

**Web site:** <http://www.sessionbrasil.com>

**Distributor for:** Brazil

## COSMIC SPORTS BV

Van Speijkstraat 2/39 - 2041 KL Zandvoort  
- Netherlands

**Phone:** +31 235735518

**Fax:** +31 235735523

**E-mail:** [info@cosmicsports.com](mailto:info@cosmicsports.com)

**Web site:** [www.cosmicsports.com](http://www.cosmicsports.com)

**Contact:** Pieter Versteeg

**Distributor for:** Belgium, Luxembourg,  
Netherlands

## EXTREME RIDERS DISTRIBUTION SRL

Bibescu Voda 1, Bl. P4 - sect. 4 Bucharest  
040151 - Romania

**Phone:** 021 / 335 6577

**Fax:** 021 / 335 5948

**E-mail:** [davidmiu\\_pitic@yahoo.com](mailto:davidmiu_pitic@yahoo.com)

**Web site:** <http://www.extremeriders.ro>

**Contact:** David Miu

**Distributor for:** Romania

## NORCO PRODUCTS LTD.

1465 KEBET WAY PORT COQUITLAM - PORT  
COQUITLAM, B.C. V3C 6L3 - Canada

**Phone:** +1 604 552 2930

**Fax:** +1 604 552 2948

**E-mail:** [robp@norco.com](mailto:robp@norco.com)

**Web site:** <http://www.norco.com>

**Distributor for:** Canada

## ANTONIN BARTONICEK

SKLADOVA 20 - 32600 PLZEN - Czech Republic

**Phone:** +42 0377240501

**Fax:** +42 0377448548

**E-mail:** [info@bartonicek.cz](mailto:info@bartonicek.cz)

**Web site:** <http://www.bartonicek.cz>

**Distributor for:** Czech Republic

## COSMIC SPORTS GmbH

Leyher Str. 47 - 90763 Fürth - Germany

**Phone:** 09 11 / 310 755 - 0

**Fax:** 09 11 / 310 755 - 55

**E-mail:** [service@cosmicsports.de](mailto:service@cosmicsports.de)

**Web site:** <http://www.cosmicsports.de>

**Distributor for:** Germany

## FIRMA HANDLOWA GREGORIO

UL.3 MAJA 24A - PL - 43-450 USTRON - Poland

**Phone:** +48 338544802

**Fax:** +48 338544802

**E-mail:** [gregorio@post.pl](mailto:gregorio@post.pl)

**Web site:** <http://www.gregorio.pl>

**Distributor for:** Lithuania, Poland

## INTERCYCLE

Pfirundmatte 3 - CH-6210 SURSEE - Switzerland

**Phone:** +41 (0)41 9266511

**Fax:** +41 (0)41 9266352

**E-mail:** [info@intercycle.com](mailto:info@intercycle.com)

**Web site:** <http://www.intercycle.com>

**Distributor for:** Liechtenstein, Switzerland

## LEADER BIKE

Lagutenko 14 - 83086 Donetsk - Ukraine

**Phone:** +380622900634

**Fax:** +380623826168

**E-mail:** [leaderfox@donapex.net](mailto:leaderfox@donapex.net)

**Web site:** <http://www.leader.dn.ua>

**Distributor for:** Ukraine

## MALI BICYCLE TECHNOLOGY

GYEPSOR U.1 H - 1211 - BUDAPEST - Hungary

**E-mail:** [mali@mali.hu](mailto:mali@mali.hu)

**Distributor for:** Hungary

## RACE COMPANY

Quartier Salignan - Le Chêne - 84400 Apt  
- France

**Phone:** +33 (0) 490044660

**Fax:** +33 (0) 490040635

**E-mail:** [contact@raceco-mtb.com](mailto:contact@raceco-mtb.com)

**Web site:** <http://www.raceco-mtb.com>

**Contact:** Christophe Morera (Momo)

**Distributor for:** France

## ID SPORT d.o.o.

Kopaliska ulica 35 - SI-4220 Skofja Loka -  
Slovenia

**Phone:** +38 631320791

**Fax:** +38 659935827

**E-mail:** [info@idsport.si](mailto:info@idsport.si)

**Distributor for:** Slovenia

## KASSIMATIS CYCLING

8, Ippodamias Sq. - 185 31 Piraeus - Greece

**Phone:** +30 210 4122596

**Fax:** +30 210 4119317

**Web site:** <http://www.kassimaticycling.gr>

**Contact:** Nikos Kassimatis

**Distributor for:** Cyprus, Greece

## MAGRI CYCLES & SPARES

155 Eucharistic Congress Road - Mosta - Malta

**Phone:** +356 21414399

**Fax:** +356 21436377

**E-mail:** [magricyc@malta.net.net](mailto:magricyc@malta.net.net)

**Distributor for:** Malta

## SERGEY GOREMYKINE

123364 - 43-91 St. Svobody - Moscow - Russia

**Phone:** +74956132938

**E-mail:** [sergey@realbiker.ru](mailto:sergey@realbiker.ru)

**Web site:** <http://www.marzocchi.ru>

**Distributor for:** Estonia, Russia

## SOLENT UK Ltd. t/a Windwave

Units D2-D3 - Heritage Business Park - Heritage  
Way - Gosport Hants PO12 4BG - United  
Kingdom

**Phone:** +44 (0)23 92521912

**Fax:** +44 (0)23 92522625

**E-mail:** [office@windwave.co.uk](mailto:office@windwave.co.uk)

**Web site:** <http://www.windwave.co.uk>

**Distributor for:** United Kingdom, Ireland

## TAVARES & TIMMERMANS, Lda. Bike Center

Condomínio Industrial de Alcolombal - Estrada de  
Alcolombal - Armazém - 12705-833 TERRUGEM-  
SINTRA - Portugal

**Phone:** +351 21 961 06 21

**Fax:** +351 21 961 06 38

**E-mail:** [bikecenter@mail.telepac.pt](mailto:bikecenter@mail.telepac.pt)

**Web site:** <http://www.bikecenter-pt.com>

**Contact:** Hans Timmermans

**Distributor for:** Portugal

**SPORTPARTNER AS**

POSTBOKS 555 - Bergen 5884 - Norway  
**Phone:** +47 (0) 55 50 64 64  
**Fax:** +47 (0) 55 50 64 65  
**E-mail:** post@sportpartner.no  
**Web site:** http://www.sportpartner.no  
**Distributor for:** Norway

**TEAM BIKE S.L.**

Elche Parque Industrial - c/ Juan de la Cierva,  
 87 - 03203 Torrellano-Elche Alicante - Spain  
**Phone:** +34 (0) 965 68 1554  
**Fax:** +34 (0) 965 68 0510  
**E-mail:** info@teambike.es  
**Contact:** Simon  
**Distributor for:** Andorra, Spain

**VELOMANIA LTD**

Gueshevo N.83 str. - Sofia 1330 - Bulgaria  
**Phone:** +359 (2) 8127063  
**Fax:** +359 (2) 8127061  
**E-mail:** info@velomania-bg.com  
**Web site:** http://www.velomania-bg.com  
**Contact:** Evgeni Tanev  
**Distributor for:** Bulgaria

**VELOSPRINT S**

Damborského 9 - 949 01 Nitra - Slovakia  
**Phone:** +42 1376578399  
**Fax:** +42 1376578398  
**E-mail:** jsladek@velosprint.sk  
**Contact:** Ing. Jan Sladek  
**Distributor for:** Slovakia

**BUMIL TRADING COMPANY**

B-08 2F KOEX 159 SAMSUNG-DONG -  
 KANGNAM-KU SEOUL - Korea  
**Phone:** 0082 2551 6992  
**Fax:** 0082 2551 6993  
**E-mail:** bumilco@chol.com  
**Distributor for:** Korea

**CV RODA LINTAS KHATULISTIWA**

RODALINK/PT INSERA SENA JALAN -  
 JAWA393DESA WADUNGASIH BUDURAN  
 - SIDOARJO EAST JAVA - Indonesia  
**Phone:** +62-318963951  
**Fax:** +62-318961781  
**E-mail:** marzocchi@rodalink.com  
**Web site:** http://www.rodalink.com  
**Distributor for:** Indonesia

**FAREN ENTERPRISES**

#59\_E Bansalangan St., Project 7 - 1105 -  
 Quezon City - Philippines  
**Phone:** +632 372 2541  
**Fax:** +632 372 2311  
**E-mail:** hans125@skydsl.com.ph  
**Distributor for:** Philippines

**ZZK**

DZELZAVAS STREET 47 - LV 1084 - RIGA  
 - Latvia  
**Phone:** +37 17703258  
**Fax:** +37 17311022  
**E-mail:** janis@zzk.lv  
**Distributor for:** Latvia

**CHUN YOUNG CYCLE CO.**

132 San Fung Av. - Ground Floor - Sheung Shui,  
 New Territories - Hong Kong SAR  
**Fax:** +852 26795602  
**E-mail:** support@hkbicycle.com.hk  
**Contact:** Mr. Jason Lee  
**Distributor for:** Hong Kong SAR

**CYCLE TRADING COMPANY LTD.**

Hapardes Rd. - RISHPON, Israel - Israel  
**Phone:** +972 9 9513010  
**Fax:** +972 9 9509783  
**E-mail:** sales@ctc.co.il  
**Web site:** http://www.ctc.co.il  
**Distributor for:** Israel

**INTERNATIONAL BICYCLE TECHNOLOGY CO., LTD/GZ**

ROOM 101, NO.3 BAO HUAN EAST ROAD -  
 FREE TRADE ZONE, GUANGZHOU - China  
**Phone:** +86-20-8208-7958  
**Fax:** +86-20-8220-9123  
**Distributor for:** China

**MOON ORIENTAL TRADING SERVICES**

NO.30, JALAN RAJA UDANG 14 - TAMAN  
 PANTAI SEPANG PUTRA - SG. PELEK,  
 SEPANG, SELANGOR - Malaysia  
**E-mail:** kshbicycle@yahoo.com  
**Distributor for:** Malaysia

**SCV IMPORTS**

PO BOX 3213 - NSW 2259 - Tuggerah -  
 Australia  
**Phone:** +61 2 4353 2633  
**Fax:** +61 2 4353 2533  
**E-mail:** service@scvimports.com.au  
**Web site:** http://www.scvimports.com.au  
**Contact:** Stuart  
**Distributor for:** Australia

**KOZAKI TRADING CO.LTD.**

28-24, Izumi 2-Chome, Higashi-Ku, (Central  
 PO Box No. 302, Nagoya, 461-0001) - Japan  
 - Nagoya, 461-0001 - Japan  
**Phone:** +81 52 931 2072  
**Fax:** +81 52 932 0474  
**E-mail:** ua@diatechproducts.com  
**Web site:** http://www.diatechproducts.com  
**Distributor for:** Japan

**RODALINK (S) Pte Ltd**

#03-07 Eunos Technolink - 7, Kaki Bukit Road 1

- 415937 Singaporev  
**Phone:** 65-6749 3239  
**Fax:** 65-6749 3531  
**E-mail:** marzocchi@rodalink.com  
**Web site:** http://www.rodalink.com  
**Contact:** Eddy Pang  
**Distributor for:** Singapore, Thailand, Vietnam

**WIDE OPEN DISTRIBUTORS LTD**

57 Brunswick Drive - Te Ngae - Rotorua - New  
 Zealand  
**Phone:** Ph + 64 7 3453280  
**E-mail:** sales@wideopen.co.nz  
**Web site:** http://www.wideopen.co.nz  
**Distributor for:** New Zealand

**C.O.I.**

1, RUE GUSTAVE EIFFEL - ZAC 2000-B.P.392 - LE  
 PORT CEDEX - Reunion  
**Phone:** 00262 262 42 21 82  
**Fax:** 00262 262 42 60 84  
**E-mail:** LauryL@coi.fr  
**Contact:** Laury  
**Distributor for:** Reunion

**HEARTY OAK TRADING 500 PTY LTD**

Abattoir Street 3 - George, 6530 - South Africa  
**Phone:** +27 44-874-0290  
**Fax:** +27 86-666-0282  
**E-mail:** danie@globacycles.com  
**Contact:** Danie Von Tonder  
**Distributor for:** South Africa

**HOSTETTLER GMBH**

Neuenburger Strasse 33  
 D-79379 Müllheim / Deutschland  
**Phone-Nr.:** + 07631-180 40  
**Fax-Nr.:** + 07631-180 499  
 www.hostettler.de  
 email contact: david.tschumi@intercycle.com

**CREDITS**

Special thanks and kudos to all the  
 people who made our 2010 OE  
 catalog possible:

Bryson Martin,  
 Andrea Pierantoni,  
 John Pelino,  
 Jessica Morisi and Lisa Bassi.

Design and concept: Neil Vilppu  
 Words and workflow: Francesco  
 Marzari  
 Photo: Ronny Kiaulehn and  
 Alessandro Di Lullo





**TENNECO**