



**SRAM**®



Level™ Ultimate, TLM & TL

Service Manual



**SRAM**®

GEN.0000000005086 Rev A  
© 2016 SRAM, LLC

# SRAM LLC WARRANTY

## EXTENT OF LIMITED WARRANTY

Except as otherwise set forth herein, SRAM warrants its products to be free from defects in materials or workmanship for a period of two years after original purchase. This warranty only applies to the original owner and is not transferable. Claims under this warranty must be made through the retailer where the bicycle or the SRAM component was purchased. Original proof of purchase is required. **Except as described herein, SRAM makes no other warranties, guaranties, or representations of any type (express or implied), and all warranties (including any implied warranties of reasonable care, merchantability, or fitness for a particular purpose) are hereby disclaimed.**

## LOCAL LAW

This warranty statement gives the customer specific legal rights. The customer may also have other rights which vary from state to state (USA), from province to province (Canada), and from country to country elsewhere in the world.

To the extent that this warranty statement is inconsistent with the local law, this warranty shall be deemed modified to be consistent with such law, under such local law, certain disclaimers and limitations of this warranty statement may apply to the customer. For example, some states in the United States of America, as well as some governments outside of the United States (including provinces in Canada) may:

- a. Preclude the disclaimers and limitations of this warranty statement from limiting the statutory rights of the consumer (e.g. United Kingdom).
- b. Otherwise restrict the ability of a manufacturer to enforce such disclaimers or limitations.

## For Australian customers:

This SRAM limited warranty is provided in Australia by SRAM LLC, 1000 W. Fulton Market, 4th Floor, Chicago, IL, 60607, USA. To make a warranty claim please contact the retailer from whom you purchased this SRAM product. Alternatively, you may make a claim by contacting SRAM Australia, 6 Marco Court, Rowville 3178, Australia. For valid claims SRAM will, at its option, either repair or replace your SRAM product. Any expenses incurred in making the warranty claim are your responsibility. The benefits given by this warranty are additional to other rights and remedies that you may have under laws relating to our products. Our goods come with guarantees that cannot be excluded under the Australian Consumer Law. You are entitled to a replacement or refund for a major failure and for compensation for any other reasonably foreseeable loss or damage. You are also entitled to have the goods repaired or replaced if the goods fail to be of acceptable quality and the failure does not amount to a major failure.

## LIMITATIONS OF LIABILITY

To the extent allowed by local law, except for the obligations specifically set forth in this warranty statement, in no event shall SRAM or its third party suppliers be liable for direct, indirect, special, incidental, or consequential damages.

## LIMITATIONS OF WARRANTY

This warranty does not apply to products that have been incorrectly installed and/or adjusted according to the respective SRAM user manual. The SRAM user manuals can be found online at [sram.com](http://sram.com), [rockshox.com](http://rockshox.com), [avidbike.com](http://avidbike.com), [truvatv.com](http://truvatv.com), or [zipp.com](http://zipp.com).

This warranty does not apply to damage to the product caused by a crash, impact, abuse of the product, non-compliance with manufacturers specifications of usage or any other circumstances in which the product has been subjected to forces or loads beyond its design.

This warranty does not apply when the product has been modified, including, but not limited to any attempt to open or repair any electronic and electronic related components, including the motor, controller, battery packs, wiring harnesses, switches, and chargers.

This warranty does not apply when the serial number or production code has been deliberately altered, defaced or removed.

This warranty does not apply to normal wear and tear. Wear and tear parts are subject to damage as a result of normal use, failure to service according to SRAM recommendations and/or riding or installation in conditions or applications other than recommended.

## Wear and tear parts are identified as:

- |   |  |                          |                      |
|---|--|--------------------------|----------------------|
| • Dust seals                                  | • Stripped threads/bolts (aluminium, titanium, magnesium or steel) | • Handlebar grips        | • Transmission gears |
| • Bushings                                    | • Brake sleeves  | • Shifter grips          | • Spokes             |
| • Air sealing o-rings                         | • Brake pads   | • Jockey wheels          | • Free hubs          |
| • Glide rings                                 | • Chains   | • Disc brake rotors      | • Aero bar pads      |
| • Rubber moving parts                         | • Sprockets  | • Wheel braking surfaces | • Corrosion          |
| • Foam rings                                  | • Cassettes  | • Bottomout pads         | • Tools              |
| • Rear shock mounting hardware and main seals | • Shifter and brake cables (inner and outer)                       | • Bearings               | • Motors             |
| • Upper tubes (stanchions)                    |  | • Bearing races          | • Batteries          |
|   |  | • Pawls                  |                      |

**Notwithstanding anything else set forth herein**, the battery pack and charger warranty does not include damage from power surges, use of improper charger, improper maintenance, or such other misuse.

This warranty shall not cover damages caused by the use of parts of different manufacturers.

This warranty shall not cover damages caused by the use of parts that are not compatible, suitable and/or authorised by SRAM for use with SRAM components.

This warranty shall not cover damages resulting from commercial (rental) use.

# TABLE OF CONTENTS

<b>BRAKE SERVICE OVERVIEW.....</b>	<b>5</b>
TROUBLESHOOTING.....	6
<b>SRAM LEVEL™ ULTIMATE &amp; TLM CALIPER SERVICE.....</b>	<b>7</b>
PARTS AND TOOLS NEEDED FOR SERVICE .....	7
LEVEL CALIPER EXPLODED VIEW .....	7
CALIPER BRAKE PAD REMOVAL.....	8
CALIPER PISTON REMOVAL .....	9
CALIPER PISTON INSTALLATION.....	13
<b>SRAM LEVEL™ TL CALIPER SERVICE.....</b>	<b>15</b>
PARTS AND TOOLS NEEDED FOR SERVICE .....	15
SRAM LEVEL TL CALIPER EXPLODED VIEW.....	15
CALIPER BRAKE PAD REMOVAL.....	16
CALIPER PISTON REMOVAL .....	17
CALIPER PISTON INSTALLATION.....	20
<b>LEVER SERVICE .....</b>	<b>23</b>
PARTS AND TOOLS NEEDED FOR SERVICE .....	23
LEVEL™ ULTIMATE LEVER EXPLODED VIEW.....	23
LEVEL™ TLM & TL LEVER EXPLODED VIEW.....	24
LEVER BLADE REMOVAL.....	25
PISTON ASSEMBLY REMOVAL.....	30
PISTON ASSEMBLY INSTALLATION .....	31
LEVER BLADE INSTALLATION .....	32



# **SAFETY FIRST!**

We care about YOU. Please, always wear your safety glasses and protective gloves when servicing SRAM® products.  
Protect yourself! Wear your safety gear!

## Brake Service Overview

SRAM brake systems need to be serviced periodically to optimize braking function. If brake fluid is leaking from any area of the brake there may be damage or wear and tear to the internal moving parts. If the system has been contaminated with the wrong fluid there may be damage to all rubber and plastic internal parts. If your brake was damaged in a crash there may be damage to the lever blade, pushrod, and brake assemblies. Inspect and replace these parts to restore proper brake function.

**Your product's appearance may differ from the pictures contained in this publication.**

## SAFETY INSTRUCTIONS

- Servicing your brakes removes all of the brake fluid from the system. You must bleed your brakes after you service the brake caliper and/or lever.
- Always wear safety glasses and nitrile gloves when working with DOT fluid.
- Place an oil pan on the floor where you will be working on the brake.
- Used DOT fluid should be recycled or disposed of in accordance to local and federal regulations.
- Never pour DOT fluid down a sewage or drainage system or into the ground or a body of water.
- DOT fluids will damage painted surfaces. If any fluid comes in contact with a painted surface (i.e. your frame) or printing on the brakes, wipe it off immediately and clean it with isopropyl alcohol or water. Damage to painted and/or printed surfaces by DOT fluid is not covered under warranty.
- Do not allow any brake fluid to come in contact with the brake pads. If this occurs, the pads are contaminated and must be replaced.
- For best results, use only SRAM DOT 5.1 fluid. If SRAM fluid is not available, only use DOT 5.1 or 4 fluid.

**Do not use mineral oil or DOT 5 fluid.**

## Troubleshooting

### 'Sticky,' slow brake pad return, or excessive lever throw

If your brakes feel sticky and exhibit slow brake pad return and/or excessive brake lever throw, it may be a result of the pistons sticking in the caliper. Before completely disassembling your caliper, you can try to loosen the sticky piston by performing the following steps:

1. Clamp the bicycle into a bicycle work stand.
2. Remove the wheel from the affected caliper.
3. Squeeze the brake lever several times until the brake pads nearly contact one another.
4. Insert the Level™ pad spreader between the brake pads to spread the pads to the full width of the clip.
5. Remove the Level pad spreader.
6. Repeat steps 3-5.
7. Reinstall the wheel.
8. Squeeze the brake lever several times to position the brake pads to the proper distance from the rotor.
9. Center the caliper on the rotor if necessary.
10. Spin the wheel and check the brake function. The pistons should move freely and there should not be excessive brake lever throw.

If there is no improvement in the brake function, proceed with caliper service.

## SRAM Level™ Ultimate & TLM Caliper Service

We recommend that you have your SRAM Level brakes serviced by a qualified bicycle mechanic. Servicing SRAM brakes requires knowledge of brake components as well as the special tools and fluids used for service.

For exploded diagram and part number information, please refer to the Spare Parts Catalog available on our website at [sram.com/service](http://sram.com/service). For order information, please contact your local SRAM distributor or dealer.

Information contained in this publication is subject to change at any time without prior notice. For the latest technical information, please visit our website at [sram.com/service](http://sram.com/service).

**Your product's appearance may differ from the pictures contained in this publication**

### Parts and Tools Needed for Service

- Safety glasses
- Nitrile gloves
- Oil pan
- Isopropyl alcohol
- Level bleed block
- SRAM monoblock caliper 21 mm piston removal tool
- Digital caliper
- SRAM DOT 5.1 Fluid
  - If SRAM fluid is not available, only use DOT 5.1 or 4 fluid
- 8mm Flare nut crowfoot wrench
- Pick
- T8 & T25 TORX® wrenchs
- T25 TORX bit socket
- Torque wrench
- 2.5 mm hex wrench
- Clean, lint-free rag
- Level pad spreader
- Air compressor with a rubber-tipped chuck nozzle
- Soft rubber or piece of inner tube
- Level pad spreader

### Level Caliper Exploded View

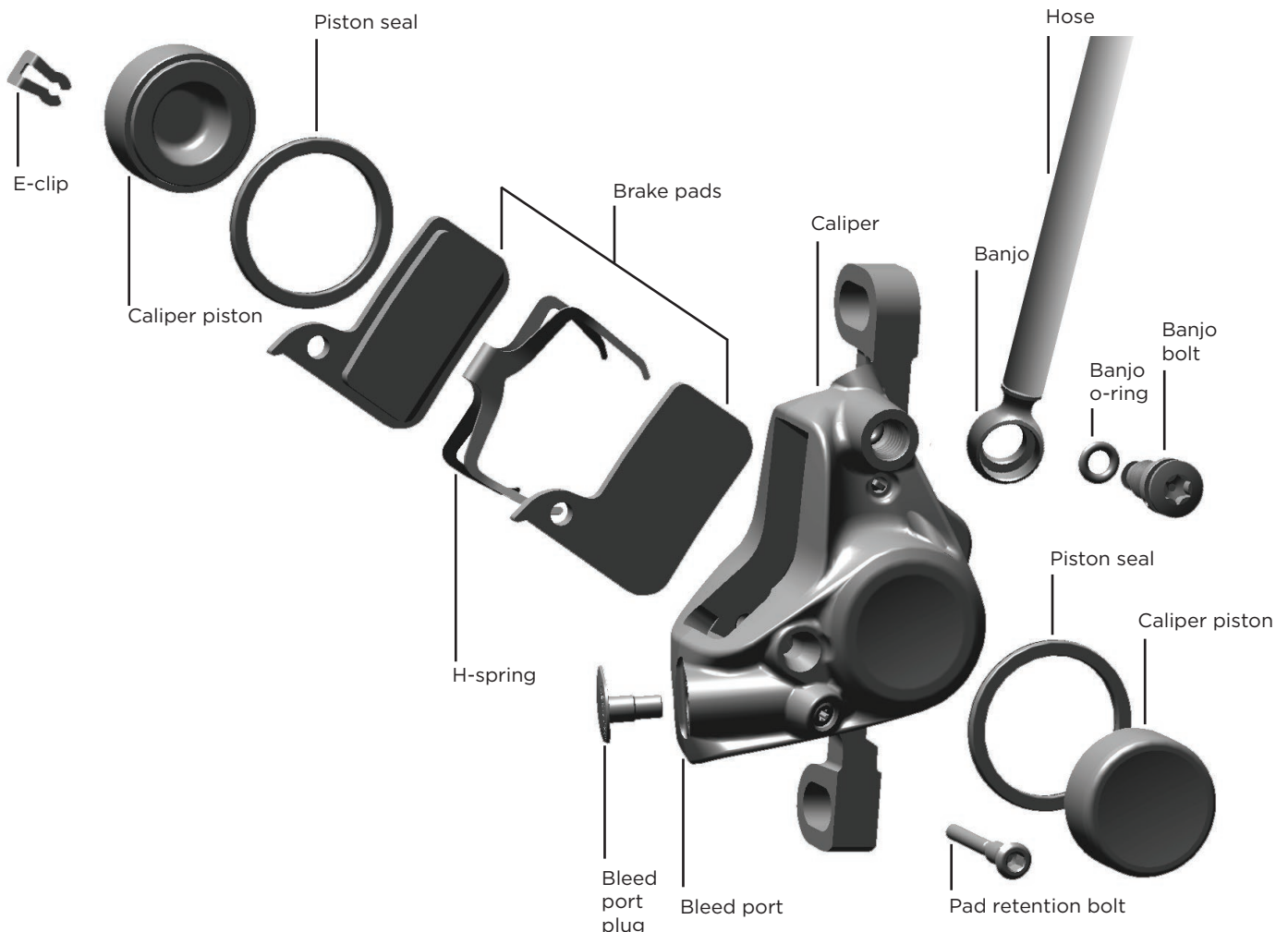

## Caliper Brake Pad Removal

### NOTICE

DOT fluid will damage painted surfaces. If any fluid comes in contact with a painted surface (i.e. your frame) or printing on the brakes, wipe it off immediately and clean it with isopropyl alcohol or water. Damage to painted and/or printed surfaces by DOT fluid is not covered under warranty.

- 1 Use a T25 TORX® wrench or a 5 mm hex wrench to remove the brake caliper from the fork or frame.  
Remove the caliper, mounting bracket, and hardware from the caliper, then set them aside in the order that they were removed.

- 2 Use needle nose pliers to remove the E-clip from the pad retention bolt.  
Use a 2.5 mm hex wrench to remove the pad retention bolt from the caliper.



- 3 Remove the brake pads from the caliper.

### NOTICE

Brake pads must be replaced if the total thickness of the backing plate and pad friction material is less than 3 mm.





## Caliper Piston Removal

### NOTICE

DOT fluid will damage painted surfaces. If any fluid comes in contact with a painted surface (i.e. your frame) or printing on the brakes, wipe it off immediately and clean it with isopropyl alcohol or water. Damage to painted and/or printed surfaces by DOT fluid is not covered under warranty.

- 1 Use a T25 TORX® wrench to remove the banjo bolt and hose.



- 2 Insert the SRAM monoblock caliper 21 mm piston removal tool, then use a 2.5 mm hex wrench to install the pad retention bolt into the caliper.



### CAUTION

The pad retention bolt must be installed. If the pad retention bolt is not installed the SRAM piston removal tool may dislodge rapidly from the caliper, which can lead to bodily injury or damage to the parts.



- 3** Firmly press a rubber-tipped air chuck nozzle into the banjo port. Hold the caliper securely against a rubber surface and force air into the banjo port to dislodge the piston from the caliper.

**⚠ CAUTION - EYE HAZARD**

Wear safety glasses.

The caliper piston may dislodge rapidly from the caliper, which can lead to bodily injury or damage to the parts. Point the caliper piston toward a rubber surface to prevent the piston from becoming a projectile.



- 4** Remove the pad retainer bolt, then remove the SRAM piston removal tool from the caliper.



- 5** Insert the Level piston plug so that it fits snugly into the empty piston bore and is flush with the inside of the caliper.



- 6 Insert the SRAM piston removal tool so that it will capture the still-installed piston. Make sure the horse-shoe opening is aligned with the tab on the piston plug.



Use a 2.5 mm hex wrench to install the pad retention bolt in order to hold the piston removal tool in place.

**CAUTION**

The pad retention bolt must be installed. If the pad retention bolt is not installed the SRAM piston removal tool may dislodge rapidly from the caliper, which can lead to bodily injury or damage to the parts.

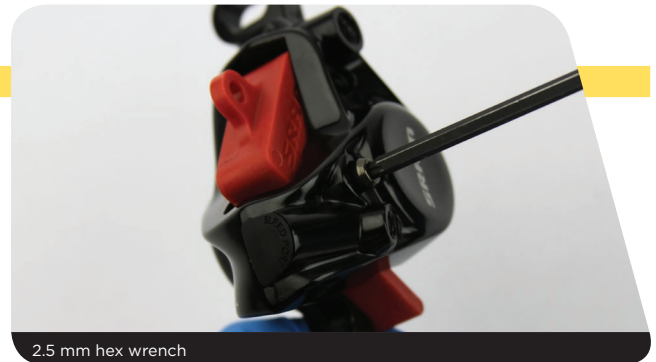

- 7 Insert a rubber-tipped blow gun chuck nozzle into the banjo port, then place a towel over the caliper to contain any dislodged fluid.

**CAUTION**

Wear safety glasses.

The caliper piston may dislodge rapidly from the caliper, which can lead to bodily injury or damage to the parts. Point the caliper pistons toward a rubber surface before forcing air into the caliper.



While firmly pushing against the caliper half and chuck nozzle, squeeze the air chuck to force air into the banjo port and dislodge the piston from the caliper.

Continue to force air into the caliper until the piston is dislodged. Turn the caliper over and the piston will fall out easily.

Remove the SRAM piston removal tool and piston plug from the caliper.

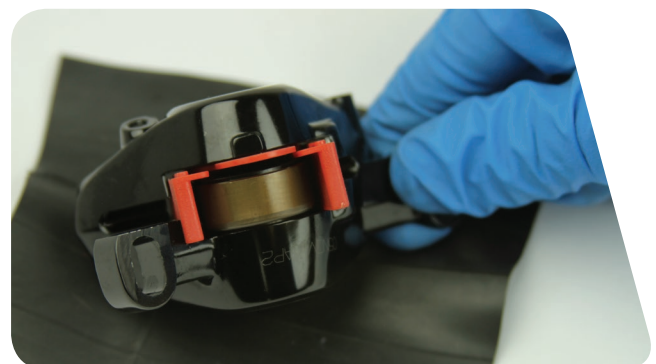

- 8** Use a pick to remove the piston seals from each piston bore. Spray isopropyl alcohol inside each piston bore and clean them with a rag. Then install new seals inside each piston bore.

**CAUTION**

Do not scratch the seal gland with the pick. Scratches could cause fluid to leak when the brake is applied, which will contaminate the brake pads and could lead to a brake failure.



Pick

- 9** Spray isopropyl alcohol on the inside and the outside of the caliper and all of the removed parts and clean them with a rag.

**NOTICE**

If the system has been contaminated with mineral oil or DOT 5 fluid, flush all of the parts with soapy water, rinse them with clean water, then allow all of the parts to dry prior to rebuilding. Install all new seals and a new brake hose.

For the best braking performance, use only SRAM DOT 5.1 fluid. If SRAM fluid is not available, use only DOT 5.1 fluid or 4 fluid.



## Caliper Piston Installation

### NOTICE

DOT fluid will damage painted surfaces. If any fluid comes in contact with a painted surface (i.e. your frame) or printing on the brakes, wipe it off immediately and clean it with isopropyl alcohol or water. Damage to painted and/or printed surfaces by DOT fluid is not covered under warranty.

- 1 Inspect the caliper pistons for damage and replace the pistons if necessary.

Use your gloved finger to apply a small amount of SRAM DOT 5.1 fluid to each piston, then install each piston into each piston bore.

### NOTICE

For the best braking performance, use only SRAM DOT 5.1 fluid. If SRAM fluid is not available, use only DOT 5.1 or 4 fluid. Do not use grease. Grease will prevent the pistons from fully retracting into the caliper bores which will reduce braking performance.

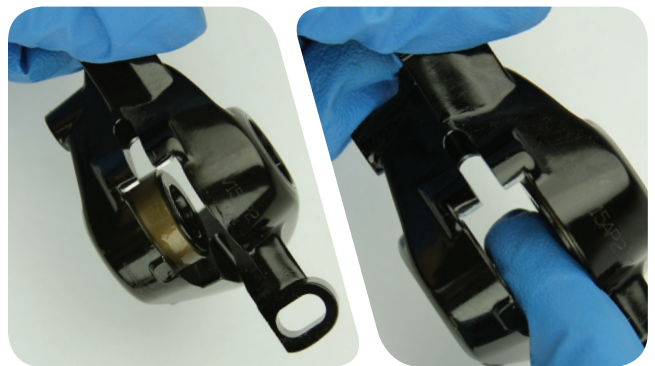

**Tip:** If a piston is difficult to install into a piston bore, lay the caliper on a flat surface. Slide a thin wrench through the caliper, then gently and evenly press the piston into the bore.



- 2 Remove the o-ring from the banjo bolt.  
Apply a small amount of SRAM DOT 5.1 fluid to the new o-rings and install them.



**3** Use a torque wrench with a T25 TORX® bit socket to tighten the bolt to 4.4-5.4 N·m (39-48 in-lb).

The angle of the hose and banjo may be adjusted by loosening the banjo bolt, adjusting it to the desired position, and then retightening the banjo bolt to 4.4-5.4 N·m (39-48 in-lb).



**4** Insert the Level™ bleed block into the caliper.



Use a 2.5 mm hex wrench to insert the pad retention bolt

### **CAUTION**

You must bleed your brakes before reinstalling the brake pads. Installing the brake pads prior to bleeding the brakes could contaminate the brake pads and could lead to a brake failure.



**5** Spray isopropyl alcohol on the caliper and clean it with a rag.



Visually check your work. If any of the o-rings protrude from the banjo fitting or banjo bolt, remove and replace the o-ring, then repeat the installation process.

## **SAFETY INSTRUCTIONS**

Servicing your brakes removes all of the fluid from the system. You must bleed the brakes after you service the brake caliper and/or lever. For brake bleed, brake hose shortening, and brake pad replacement instructions, visit [www.sram.com/service](http://www.sram.com/service).

## SRAM Level™ TL Caliper Service

### Parts and Tools Needed for Service

- Safety glasses
- Nitrile gloves
- Flare nut crowfoot socket and wrench
- SRAM DOT 5.1 fluid
  - If SRAM fluid is not available, only use DOT 5.1 or 4 fluid.
- Oil pan
- Flat blade screwdriver
- Torque wrench
- Air compressor with a rubber-tipped chuck nozzle
- 5 mm hex bit socket
- 2.5 mm and 5 mm hex wrenches
- Pick
- Clean, lint-free rag
- Isopropyl alcohol
- Soft rubber or piece of inner tube

### SRAM Level™ TL Caliper Exploded View

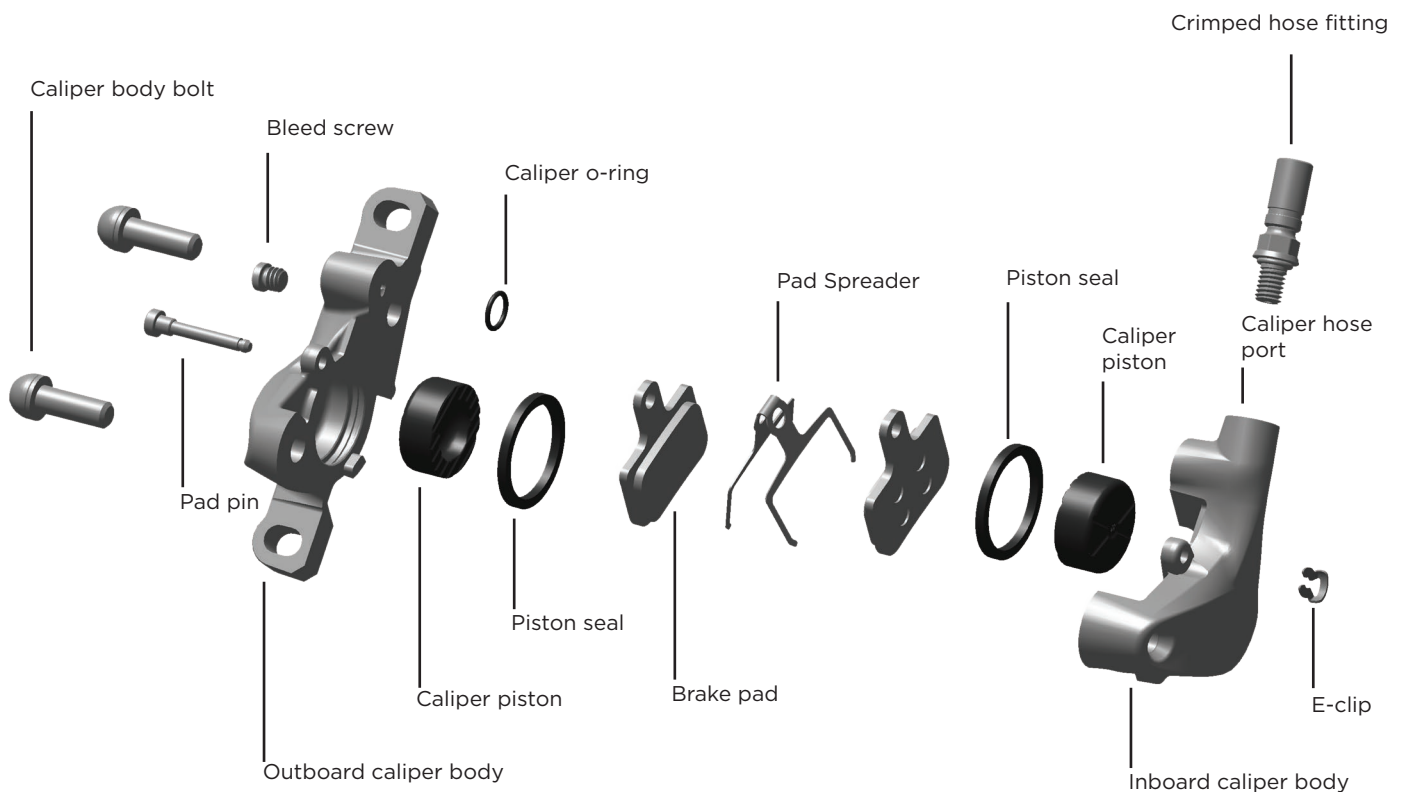

## Caliper Brake Pad Removal

### NOTICE

DOT fluid will damage painted surfaces. If any fluid comes in contact with a painted surface (i.e. your frame) or printing on the brakes, wipe it off immediately and clean it with isopropyl alcohol or water. Damage to painted and/or printed surfaces by DOT fluid is not covered under warranty.

- 1 Use a 5 mm hex wrench to remove the brake caliper from the fork or frame.

Remove the caliper mounting bracket and hardware from the caliper then set the bracket and hardware aside in the order they were removed.

- 2 Use needle nose pliers to remove the E-clip from the pad pin.  
Use a 2.5 mm hex wrench to remove the pad pin from the caliper.

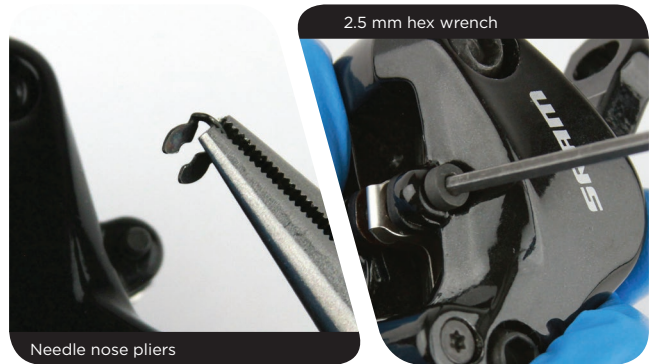

- 3 Pull the brake pads out of the caliper.

### NOTICE

Brake pads must be replaced if the total thickness of the backing plate and pad friction material is less than 3 mm.





## Caliper Piston Removal

### NOTICE

DOT fluid will damage painted surfaces. If any fluid comes in contact with a painted surface (i.e. your frame) or printing on the brakes, wipe it off immediately and clean it with isopropyl alcohol or water. Damage to painted and/or printed surfaces by DOT fluid is not covered under warranty.

- 1 Use an 8 mm flare nut crowfoot wrench to remove the crimped hose fitting.  
Pull the brake hose and crimped hose fitting from the caliper hose port.  
*Brake fluid will leak, so hold the caliper over a container to catch the fluid.*

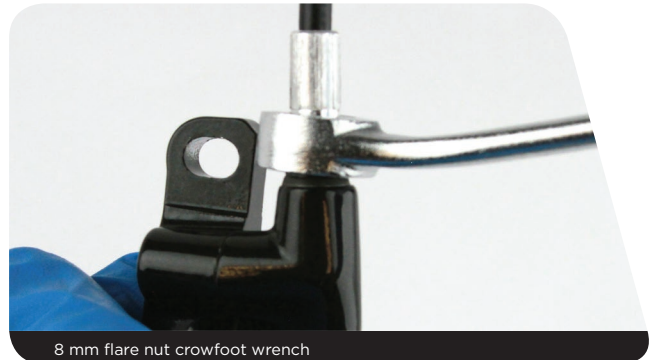

- 2 Use a 5 mm hex wrench to remove the caliper body bolts.



- 3 Separate the caliper body halves.



- 4 Use a T10 TORX® wrench to remove the bleed screw.



- 5** Place the inboard caliper half, piston side down, on a soft rubber mat or a small section of inner tube on a flat surface.  
Insert a rubber-tipped blow gun chuck nozzle into the caliper hose port.

**CAUTION - EYE HAZARD**

Wear safety glasses.

The caliper piston may dislodge rapidly from the caliper, which can lead to bodily injury or damage to the parts. Point the caliper piston toward a rubber surface before forcing air into the caliper.

While firmly pushing against the caliper half and chuck nozzle, squeeze the air chuck to force air into the caliper hose port and dislodge the piston from the caliper.

Continue to force air into the caliper until the piston is dislodged.  
Remove the piston from the caliper.



- 6** Place the outboard caliper body half, piston side down, on a soft rubber mat or a small section of inner tube on a flat surface.  
Insert a rubber-tipped blow gun chuck nozzle into the bleed screw opening.

**CAUTION - EYE HAZARD**

Wear safety glasses.

The caliper piston may dislodge rapidly from the caliper, which can lead to bodily injury or damage to the parts. Point the caliper piston toward a rubber surface before forcing air into the caliper.

While firmly pushing against the caliper half and chuck nozzle, squeeze the air chuck to force air into the bleed screw opening and dislodge the piston from the caliper.

Continue to force air into the caliper until the piston is dislodged.  
Remove the piston from the caliper.

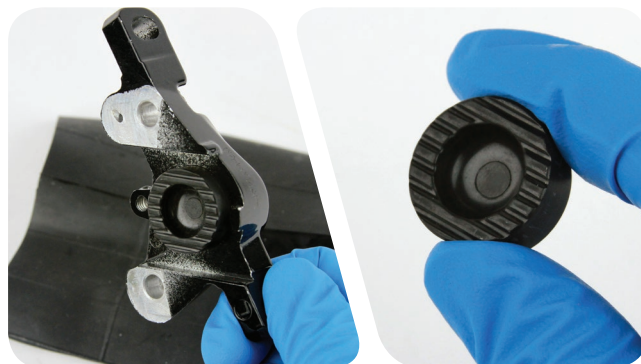

**7** Use a pick to remove the piston seal from inside both the inboard and outboard half of the caliper body.

Spray isopropyl alcohol into the caliper piston bores, and clean them with a rag. then install a new seal inside each caliper body half.

**NOTICE**

Do not scratch the seal gland with a pick. It could result in a slow fluid leak when the brake is applied.

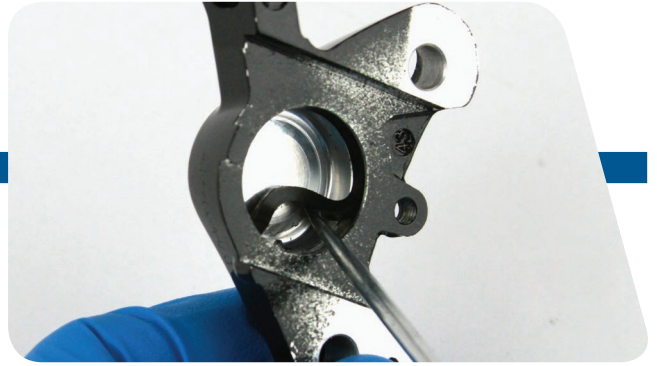

## Caliper Piston Installation

### NOTICE

DOT fluid will damage painted surfaces. If any fluid comes in contact with a painted surface (i.e. your frame) or printing on the brakes, wipe it off immediately and clean it with isopropyl alcohol or water. Damage to painted and/or printed surfaces by DOT fluid is not covered under warranty.

- 1 Inspect the caliper pistons for damage and replace the pistons if necessary.

Use your gloved finger to apply a small amount of SRAM DOT 5.1 fluid to each piston, then install each piston into each piston bore.

### NOTICE

For the best braking performance, use only SRAM DOT 5.1 fluid. If SRAM fluid is not available, use only DOT 5.1 or 4 fluid. Do not use grease. Grease will prevent the pistons from fully retracting into the caliper bores, which will reduce braking performance.



- 2 Spray isopropyl alcohol on the caliper halves and both of your gloves, and clean them with a rag.

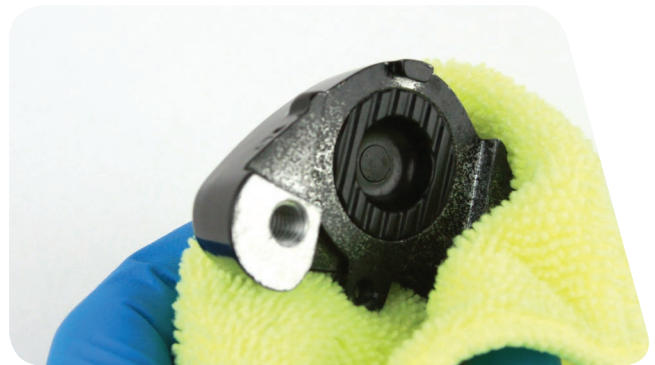

- 3 Use a pick to remove the caliper o-ring from the inboard caliper half and install a new o-ring.

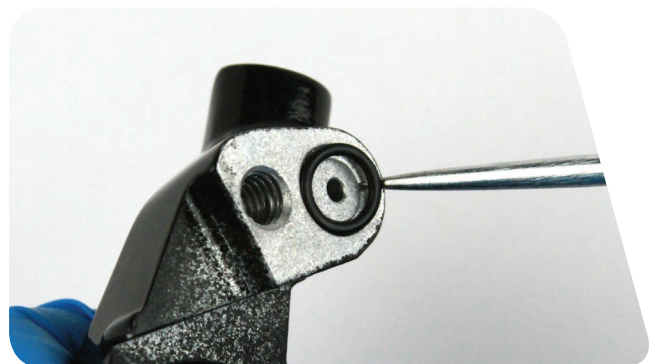

- 4** Use a pick to remove the o-ring from the crimped hose fitting. Apply a small amount of DOT 5.1 fluid to the new o-ring and install it.



- 5** Align the caliper body halves together, then thread the caliper body bolts into the caliper by hand.



- 6** Use a torque wrench with a 5 mm hex bit socket to tighten each bolt to 9.8-11.8 N·m (87-104 in-lb).



- 7** Use a T10 TORX® wrench to install the bleed screw.



- 8 Use a torque wrench with an 8 mm flare nut crowfoot socket to tighten the crimped hose fitting into the caliper hose port to 9.8-11.8 Nm (86-104 in-lb).



- 9 Insert the bleed block into the caliper.

**CAUTION**

You must bleed your brakes before reinstalling the brake pads. Installing the brake pads prior to bleeding the brakes could contaminate the brake pads and could lead to a brake failure.



- 10 Spray isopropyl alcohol on the caliper and clean it with a rag.



Visually check your work. If an o-ring protrudes from the crimped hose fitting, remove and replace the o-ring, then repeat the installation process.

**NOTICE**

Overhauling the caliper removes all of the fluid from the caliper. You must bleed the brakes for optimal performance. For brake bleed, brake hose shortening, and brake pad replacement instructions, visit [www.sram.com/service](http://www.sram.com/service).

## Lever Service

### Parts and Tools Needed for Service

- Safety glasses
- Nitrile gloves
- Oil pan
- Isopropyl alcohol
- Clean, lint-free rag
- SRAM DOT 5.1 fluid
  - If SRAM fluid is not available, only use DOT 5.1 or 4 fluid.
- Needle nose pliers
- Long-tipped snap ring pliers
- Pick
- T8, T10, & T25 TORX® wrench
- T10 TORX bit socket
- 8 mm flare nut crowfoot wrench
- Torque wrench
- SRAM aftermarket tool - lever pivot tool
- Rubber mallet

### Level™ Ultimate Lever Exploded View

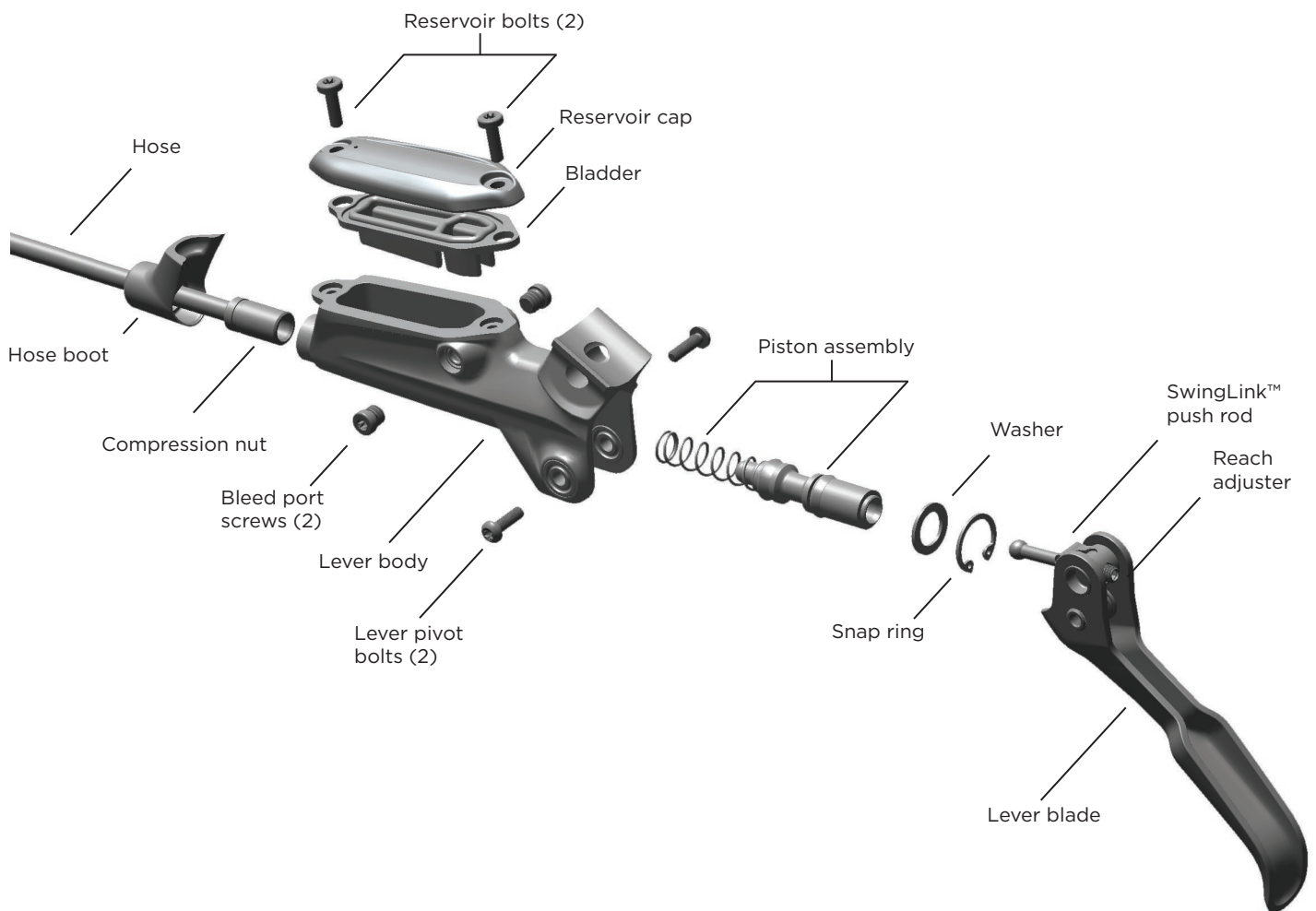

# Level™ TLM & TL Lever Exploded View

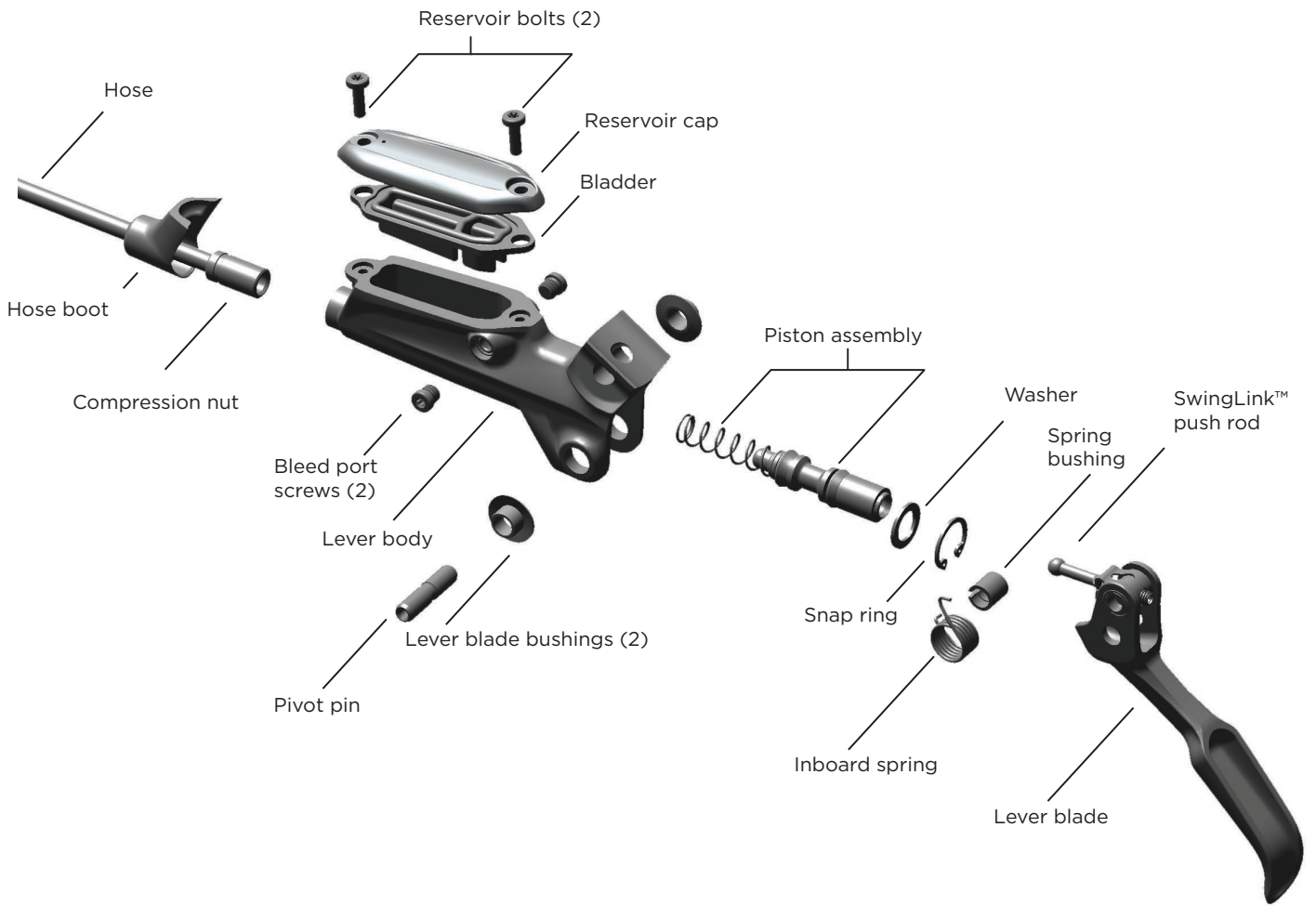



## Lever Blade Removal

### NOTICE

DOT fluid will damage painted surfaces. If any fluid comes in contact with a painted surface (i.e. your frame) or printing on the brakes, wipe it off immediately and clean it with isopropyl alcohol or water. Damage to painted and/or printed surfaces by DOT fluid is not covered under warranty.

**1** Use a T25 TORX® wrench or a 4 mm hex wrench to remove the brake clamp bolt from the discrete clamp, MMX, or XLoc™ (XLoc requires removal of the shifter) and remove the brake lever from the handlebar.

**2** Pull the hose boot away from the brake body to expose the compression nut, then slide the boot down the brake hose.



**3** Use an 8 mm flare nut crowfoot wrench to unthread the hose compression nut, then pull the brake hose and compression fitting from the brake lever body.



**4** Use a T10 TORX® wrench to remove the reservoir cap bolts from the reservoir cap.



- 5** Remove the reservoir cover and bladder from the lever body.



- 6** Pour the remaining brake fluid into an oil pan. Squeeze the lever blade to force any remaining brake fluid out of the lever body.

### NOTICE

If the system has been contaminated with mineral oil or DOT 5 fluid, flush all of the parts with soapy water, rinse with clean water, then allow all of the parts to dry prior to rebuilding.

Install all new seals and a new brake hose.

For the best braking performance, use only SRAM DOT 5.1 fluid. If SRAM fluid is not available, use only DOT 5.1 fluid or 4 fluid.

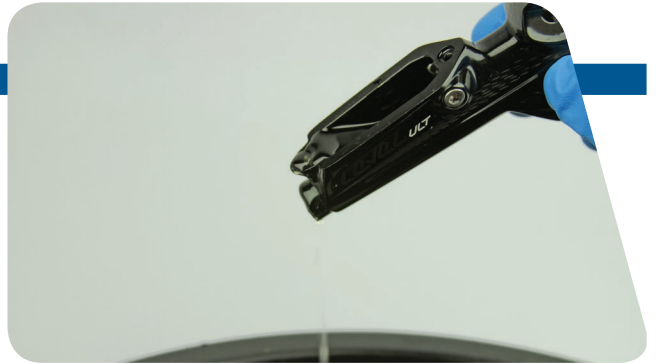

- 7** Separate the bladder from the reservoir cover.

Spray isopropyl alcohol on the bladder and the reservoir cover, then clean them with a rag.

### NOTICE

All components must be completely dry before reinstalling them. Moisture residue from cleaning the bladder can leak out of the bladder as it dries, which can be misinterpreted as a system leak, when it is not.



**8 Ultimate:** Use a T10 TORX® wrench to remove each lever pivot bolt.

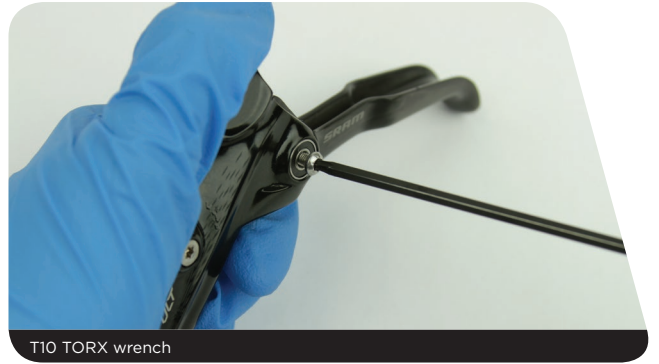

**TLM/TL:** Use a 2 mm hex wrench to rotate the reach adjust counter-clockwise and set the reach adjust position to the minimum setting.



**TLM/TL:** Place the lever body on the edge of a table, allowing the pivot pin to hang off of the side of the table, then insert the SRAM aftermarket lever pivot tool into the pivot pin slot.



**TLM/TL:** Use a plastic mallet to tap the pivot pin until it dislodges from the lever body completely.



**9** Remove the inboard spring from the spring hole.



**10** Remove the lever blade from the lever body.



**TLM/TL:** The spring and spring bushing will separate from the lever blade. Insert a new spring bushing into the spring.



**17** **TLM/TL:** Remove the lever blade bushings from the lever body and replace with new lever blade bushings.



## Piston Assembly Removal

- 1** Use long-tipped internal snap ring pliers to compress the piston assembly into the lever body as you remove the snap ring.

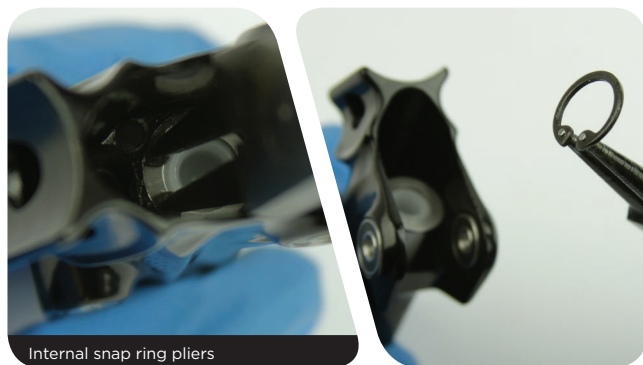

Internal snap ring pliers

Remove the washer located beneath the snap ring.



- 2** Remove the piston assembly.



- 3** Spray isopropyl alcohol on and in the lever body, the lever blade, and both of your gloves, then clean them with a rag.

## Piston Assembly Installation

### NOTICE

DOT fluid will damage painted surfaces. If any fluid comes in contact with a painted surface (i.e. your frame) or printing on the brakes, wipe it off immediately and clean it with isopropyl alcohol or water. Damage to painted and/or printed surfaces by DOT fluid is not covered under warranty.

- 1** Submerge the new piston assembly in SRAM DOT 5.1 fluid.  
If SRAM fluid is not available, only use DOT 5.1 or 4 fluid.



- 2** Insert the piston assembly into the lever body.  
Spray isopropyl alcohol on the lever body and both of your gloves, then clean them with a rag.



- 3** Install the washer on the piston assembly.  
Use long-tipped internal snap ring pliers to push the piston assembly into the lever body, and secure the snap ring in the lever body.

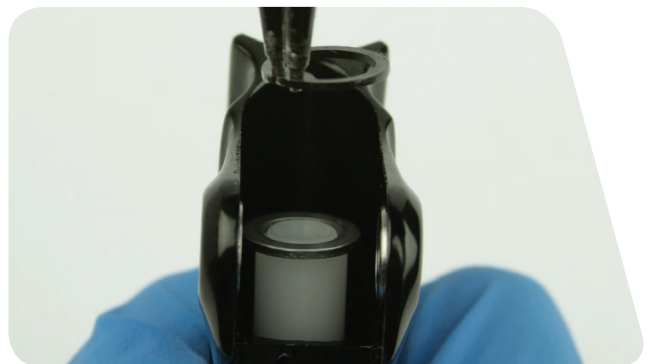

## Lever Blade Installation

- 1 TLM/TL:** Insert the lever spring and bushing into the lever blade so that one end of the spring is braced against the lever blade and the other extended beyond the blade.

*Hold the spring and bushing in place throughout the lever installation process.*



- 2** Insert the push rod into the piston that is inside the lever body.



- 3** Insert the hooked end of the spring into the spring hole in the lever body.

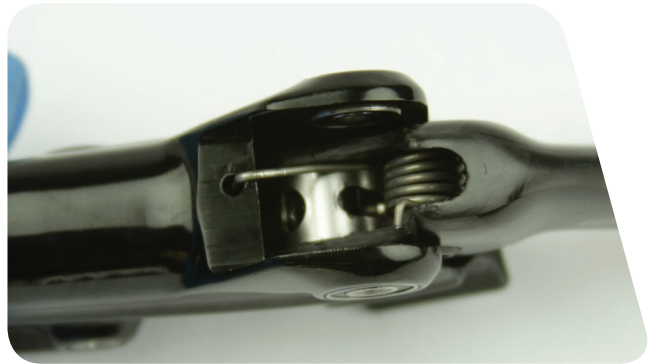



**4 Ultimate:** Make sure the holes in the spring, bushing, and lever blade align with the pivot bolt holes in the lever body.

Use a T10 TORX® wrench to thread each new pivot bolt into the bearings on each side of the lever body until they are hand tight.



**TLM/TL:** Insert the pin on the AM SRAM TOOL LEVER PIVOT Tool through the lever body bushings, lever spring, and the spring bushing.

Insert the pin on the AM SRAM TOOL LEVER PIVOT Tool onto the pivot pin.



Push the pivot pin through the lever body so that it is flush with the lever body on both sides.

Remove the pivot pin tool.



**5 Ultimate:** Use a torque wrench and a T10 TORX® bit socket to tighten each pivot bolt to 1-1.3 N·m (10-11 in-lb).



**6** Press the bladder into the reservoir cap. The bladder must be flush with the edge of the cap to be properly installed.



**7** Place the reservoir cap/bladder assembly onto the lever body.



**8** Use a torque wrench and a T10 TORX® bit socket to tighten each reservoir cap bolt to 1-1.3 N·m (10-11 in-lb).



- 9 Spray isopropyl alcohol on the lever body and clean it with a rag.



**This concludes the Level™ Ultimate, Level TLM, and Level TL Brake Service.**

### **NOTICE**

You must bleed the brakes for optimal performance. For brake bleed, brake hose shortening, and brake pad replacement instructions, visit [www.sram.com/service](http://www.sram.com/service).

This publication includes trademarks and registered trademarks of the following companies:

TORX® is a registered trademark of Acument Intellectual Properties, LLC

# **SRAM**<sup>®</sup>

[www.sram.com](http://www.sram.com)

“We will revolutionize the relationship that our users have with SRAM products, cultivating a bond between the rider and bicycle. Our technical communication will be delivered in innovative and exciting ways, with deliberation and accuracy that inspires loyalty and trust across the globe.”

-SRAM TechCom Vision Statement



ASIAN HEADQUARTERS  
SRAM Taiwan  
No. 1598-8 Chung Shan Road  
Shen Kang Hsiang, Taichung City  
Taiwan R.O.C.

WORLD HEADQUARTERS  
SRAM LLC  
1000 W. Fulton Market, 4th Floor  
Chicago, Illinois 60607  
USA

EUROPEAN HEADQUARTERS  
SRAM Europe  
Paasbosweg 14-16  
3862ZS Nijkerk  
The Netherlands